



**"Soms moet er iets gebeuren voordat er iets gebeurt."**

*- J. Crujff*

●

○



RIJKSUNIVERSITEIT GRONINGEN

# Soccer tactics

## Dynamics of small-sided games and full-sized matches

Proefschrift

ter verkrijging van het doctoraat in de  
Medische Wetenschappen  
aan de Rijksuniversiteit Groningen  
op gezag van de  
Rector Magnificus, prof. dr. E. Sterken,  
in het openbaar te verdedigen op  
maandag 26 november 2012  
om 14.30 uur

door

Wouter Gijsbert Petrus Frencken  
geboren op 6 augustus 1982  
te Tilburg

Promotor:  
Copromotor:

Prof. dr. C. Visscher  
Dr. K.A.P.M. Lemmink

Beoordelingscommissie:

Prof. dr. R.L. Diercks  
Prof. dr. R.H. Koning  
Prof. dr. G.J.P. Savelsbergh



All research presented in this thesis has been conducted at the Center for Human Movement Sciences, part of the University Medical Center Groningen, University of Groningen, the Netherlands.

The printing of this thesis was financially supported by the graduate school for Behavioral and Cognitive Neurosciences, the graduate school of Medical Sciences, the University of Groningen and the Dutch Olympic Committee



Nederlands  
Olympisch Comité  
Nederlandse  
Sport Federatie

Paranimfen:  
Michel Brink  
Thomas Frencken

Layout/Cover design:  
Thomas Frencken  
Printed by:  
Ipskamp drukkers  
ISBN:  
978-90-367-5854-3  
ISBN Digital:  
978-90-367-5855-0

© Copyright 2012: W.G.P. Frencken, Groningen, the Netherlands.  
All rights reserved. No part of this publication may be reproduced in any form or by any means, electronic or mechanical, including photocopy, recording or any information storage or retrieval system, without prior written permission of the copyright owner.

# TABLE OF CONTENTS

Page 10 to 19	Chapter 1 – General introduction <i>Adapted version from: Lemmink, K.A.P.M. &amp; Frencken, W.G.P. (Accepted). Tactical performance analysis in invasion games: Perspectives from a dynamical systems approach with examples from soccer. Routledge Handbook of Sports Performance Analysis (Eds. McGarry, T., O'Donoghue, P. &amp; Sampaio, J.)</i>
Page 22 to 31	Chapter 2 <i>Frencken, W.G.P., Lemmink, K.A.P.M. &amp; Delleman, N. (2010). Soccer-specific accuracy and validity of the local position measurement (LPM) system. Journal of Science and Medicine in Sport, 13, 641-645.</i>
Page 34 to 49	Chapter 3 <i>Frencken, W.G.P., Lemmink, K.A.P.M., Delleman, N.J. &amp; Visscher, C. (2011). Oscillations of centroid position and surface area of soccer teams in small-sided games. European Journal of Sport Science, 4, 215-223.</i>
Page 52 to 67	Chapter 4 <i>Frencken, W.G.P., De Poel, H.J., Visscher, C. &amp; Lemmink, K.A.P.M. (2012). Variability of inter-team distances associated with match events in elite-standard soccer. Journal of Sports Sciences, 30(12), 1207-1213.</i>
Page 70 to 83	Chapter 5 <i>Frencken, W.G.P., Van der Plaats, J., Visscher, C. &amp; Lemmink, K.A.P.M. (Accepted). Size matters; pitch dimensions constrain inter-team distances and surface area difference in small-sided soccer games. Journal of Systems Science and Complexity; Complex Systems and Sports.</i>
Page 86 to 95	Chapter 6 <i>Frencken, W.G.P., De Poel, H.J., Visscher, C. &amp; Lemmink, K.A.P.M. (Submitted). Inter-team distances and their variability in elite-standard soccer matches. International Journal of Performance Analysis in Sport.</i>
Page 98 to 107	Chapter 7 – General discussion
Page 110 to 111	Summary
Page 112 to 115	Samenvatting
Page 118 to 119	Curriculum Vitae
Page 120 to 123	List of publications
Page 126 to 127	Dankwoord



# GENERAL INTRODUCTION

## *Performance analysis*

Performance analysis is the objective recording and examination of behavioural events of one or more players during competition or training. Its primary goal is to provide information to coaches and players about team and/or player performance in order to plan subsequent practices to improve performance or to support preparation for the next match (Maslovat & Franks, 2008; Carling *et al.*, 2009). Depending on the goal, information on performance can be obtained from a biomechanical, technical, physiological or tactical perspective. Most scientific studies have focused on the former three domains. Although a handful of studies within these domains incorporated tactical elements, the magnitude and impact are limited. Thus, no attention has been paid specifically to tactics or tactical concepts. This thesis aims to fill that gap. Because the currently available body of knowledge on soccer performance is extremely valuable and has enhanced our understanding of soccer, two approaches that have dominated the scientific performance analysis community over the last decades will be discussed briefly.

## *Time-motion analysis*

Time-motion analysis focuses on the frequency, duration and intensity of the different movement activities during competition and

training to quantify the specific physiological requirements of the sport. Players' movements are categorized according to the intensity of the movement activities, e.g. standing, walking, jogging, running, and sprinting. More recently, various technologies are used to gather more detailed information on distance covered, speed and sporadically accelerations (e.g. Tjeldink *et al.*, 2011). In soccer, a large amount of research has been performed in which early studies focused on frequencies of specific movement activities, e.g. number of sprints completed. This has evolved to increasingly detailed evaluations of position-specific demands and comparisons of successful and elite-standard players and teams versus their less successful and sub-elite counterparts. More recently, field studies are performed to establish which aspects influence the physical match performance. This includes tactical aspects like player dismissals, substitutes and opposition formation. All physiology-oriented research has been well documented and reviewed in recent years (e.g. Carling *et al.*, 2005; Carling *et al.*, 2008; Stolen *et al.*, 2005). Although there seem to be specific requirements for different playing standards, research indicates that physical performance is strongly interrelated with many other factors. Factors that have been neglected are the strategy and tactics that players and teams

adopt during a match. This warrants further research, especially because small-sided soccer games are frequently used as a physical training stimulus, but also as a tactical training drill. Again, the physiological responses of players to small-sided games are thoroughly investigated (Hill-Haas *et al.*, 2011), but tactical merits are unclear and understudied.

#### *Notational analysis*

An alternative approach that offers feedback on performance is notational analysis. This method creates a permanent record of predominantly the on-the-ball actions of players during a match through manual or computerized notation systems. First, all behaviours, i.e. performance indicators, that players can display in a match are determined. Detail levels may vary, depending on the analyst's skill, computer software or relevance for coaches or scientists. So, extensive flowcharts are created for all performance indicators. Systematic observations of series of matches lead to the production of a large database. This database allows for feedback on various levels such as individual players, sub-units like attackers and complete teams or timescales like 15-minute periods, a complete match or series of matches. Such databases even have the potential to serve as a powerful basis for norm score development and possibly reveal signature-playing styles of teams. Likewise time-

motion analysis, a vast body of notational analysis literature is available. Again, research on performance indicators has focused on various levels of analysis and successful and elite performers versus unsuccessful and sub-elite performers. Also, isolated effects of specific factors potentially influencing performance have been subject of investigation like the home-ground advantage. Despite the availability of large databases, these analyses are straightforward. Some advances are made in the tactical domain by evaluating the temporal (sequences of events) or spatial (event locations) component. However, databases can be explored in much more detail, by using complex methodological procedures like Neural Networks (Duch *et al.*, 2010; Passos *et al.*, 2011) or T-patterns (Borrie *et al.*, 2002). Despite the limited availability of studies that provide evidence from such approaches, they seem promising to expand our knowledge on performance, specifically in the tactical domain. Nevertheless, notational analysis has certain limitations for tactical match analysis.

#### *Limitations*

Despite attempts in some time-motion and notational analysis studies to incorporate tactical elements, three major limitations from a tactical perspective are present. These need to be considered for correct interpretations of

performance using time-motion analysis or notational analysis. First, performance indicators are interrelated. Therefore, such reductionist approaches that isolate specific physiological or technical aspects lack validity when related to actual performance and can limit the development of our understanding of sports. Second, temporal and spatial factors are largely neglected. This impairs match analysis, as understanding time-evolution of performance, e.g. in a match or between matches, is key to coaches and sport scientists. Third, it can be argued that the team is more than the sum of its parts and that team performance is not equivalent to the sum of individual players' physical or on-ball performance. Therefore, the interaction processes between players of the same team or different teams, groups of players and between teams, underlie performance. Improved understanding of these interactions can enhance our understanding of team sports like soccer. Thus, tactical performance analysis refers to an evaluation of one or more performance indicators of (groups of) players that are coordinated with others. These performance indicators need to be evaluated in time and space and during attack, defence and transition phases. Finally, they must be associated with the goal to win the match. For evaluation of tactical performance and interaction processes between

players or teams, positional data obtained with tracking systems may provide a solution.

### *Positional data*

Technological innovations have resulted in ever advancing (semi) automatic tracking systems. Positional data of increasing quality is becoming available rapidly in soccer. This contains high-resolution spatio-temporal information of players in training and matches. The data can be used to calculate physical demands from covered distances and running speeds, but also allows for analysis of configurations of the players that reflect the interaction processes between the players and the ball. Spatio-temporal patterns emerge from this. Up to date, three different tracking technologies can be distinguished: GPS, (semi-) automatic video tracking and electronic tracking. Each of these technologies comes with pros and cons (see Carling *et al.*, 2005; 2009). Recently, other technologies for player tracking are proposed, including the use of infrared-textile (Silva *et al.*, 2011) or pressure-sensitive floors.

Video-based systems, such as ProZone®, AMISCO Pro® or SportVU® generally require the installation of multiple cameras that cover the whole playing surface. An extensive calibration procedure makes sure that there is overlap between the cameras'

images, which in turn allows for calculation of player positions from the camera viewpoints. An operator is required to improve tracking accuracy and real-time availability of data is restricted.

Differential or non-differential GPS-based tracking systems, e.g. GPSports, make use of satellites to calculate player positions. Players need to wear a vest or belt that contains a sensor that communicates with orbiting satellites. Its use is limited to outdoor activities only because of poor indoor signal reception. In outdoor conditions, signal reception is seriously influenced by satellite positions and weather conditions. However, it is the most affordable tracking technology at this moment.

Electronic tracking systems operate in a similar way to GPS, however tracking takes place in a confined volume with local receivers surrounding the playing surface. Electronic tracking systems, such as the local position measurement (LPM) system, require tagging players electronically by way of a vest that contains antennas and a transponder to track players' movements by means of radio frequent signals. Unfortunately, electronic aids and the equipment of players with tracking technology or other devices are not allowed in official soccer matches currently. This restricts its applicability to a training setting. For evaluation of athletes' physical

performance, advantages and disadvantages of tracking systems are nicely documented (e.g. Barris & Button, 2008; Carling *et al.*, 2008; Dobson & Keogh, 2007). However, for evaluation of tactical performance no information is available.

Next to the working mechanisms, advantages and disadvantages of the different technologies, the quality of data provided is crucial in performance evaluation. As such, validity and reliability play a prominent role. Regarding validity, differences are observed across technologies (e.g. Edgecomb & Norton, 2006; Randers *et al.*, 2010). Most frequently, tracking technologies are validated by players that walk or run fixed, predetermined distances. The distances covered measured by a tracking system are compared to the predetermined distances that serve as the 'gold standard'. The scientific evidence generally indicates high levels of agreement between the gold standard and the tracking system, regardless of technology (e.g. MacLeod *et al.*, 2009; DiSalvo, 2006). However, when systems are compared with each other, differences are observed for a series of variables including total distance covered. This holds for mutual comparisons of video systems and GPS systems (Randers, 2010), but also holds when GPS systems are compared to video systems (Edgecomb & Norton, 2006; Randers *et al.*,

2010). So, systematic errors are present and data of these systems cannot be used interchangeably. Because the limited availability of electronic tracking systems, similar comparisons across systems have not yet been completed. Possibly, the systematic error is also present when electronic tracking technologies are compared with other technologies.

Limited data is available on the reliability of the various technologies. Hand-based video tracking systems demonstrate good values of inter- and intra-user reliability in collecting positional data (e.g. Serrano & Fernandes, 2011). Likewise, high levels of absolute and relative reliability were observed for a computerized video tracking system (Di Salvo *et al.*, 2006). However, less convincing results are present for GPS devices, as considerable differences are observed between devices of the same technology. Yet, differences tend to be smaller when new and high-frequency GPS-devices of 10 Hz are concerned (Varley *et al.*, 2012). Two other important aspects of tracking systems need to be addressed. First, accuracy, or precision of measurement, is reported seldom. Second, tracking systems have difficulty in measuring players' positions at high running speeds (Coutts & Duffield, 2010), possibly caused by low sampling frequencies. GPS units' sampling frequency varies from 1 to 10 Hz, whereas semi-

automatic video tracking varies between 15 and 25 Hz. Electronic systems generally operate at 25 Hz or higher. Thus, the accuracy refers to the spatial resolution of a system, whereas the sampling frequency refers to the temporal resolution. In order to provide meaningful answers to a wide variety of research questions or practically orientated issues, both temporal and spatial resolution of tracking systems need to be considered.

For evaluation of tactics, both the temporal and spatial resolution of positional data needs to be high. Most likely, in specific match situations like free kicks, a couple of centimeters may determine the correct or incorrect relative position of the player. Furthermore, as tactics are strongly related to the position of the ball in the field, it is clear the ball position needs to be incorporated in data collection and data analysis. Up to date, various technologies are unable to accurately track ball position and as such, no evidence has been provided on ball position. Currently, the only way to collect ball data is after a time-consuming post-processing procedure. Despite the fact that accurate ball data is not yet available, first exploits of tactically related research using positional data can be realized.

## *Spatio-temporal pattern analysis*

It is evident that spatial and temporal information from time-motion and notational analysis lacks accuracy to analyze in-depth tactical performance. In addition, the behaviour of players in training or matches is brought about by interactions with teammates and opponents in a sport-specific context. So, team sports like soccer are invasion games, which implies that they are of complex nature where technical, physical, mental and tactical components are inter-related. Positional data of players provides a mean to analyze the complex nature, because the positions of individual players on the pitch, or changes in position, reflect the interaction of a player with its environment (Passos *et al.*, 2011). It can be anticipated that many aspects of performance are incorporated. For example, the direction in which a player moves reflects his decision to move in that particular direction. Furthermore, the speed or acceleration by which a player changes position may represent his physical status. Finally, the interaction between the players is reflected by the configuration of the players on the field. As a match evolves, the continuous positional changes cause complex spatio-temporal patterns to emerge.

The dynamical systems approach has shown to be useful for under-

standing spatio-temporal patterns in individual and team sports (e.g. Gréhaigne *et al.*, 1997; Lames *et al.*, 2008; McGarry *et al.*, 1999; McGarry *et al.*, 2002; McGarry, 2005; Palut & Zanone, 2005; Reed & Hughes, 2006). The core of this theory is that behaviour of a system is brought about by interactions of many subsystems. The dependent variable, or collective variable, describes the state of the system. Theoretically, the number of independent variables is unlimited. More independent variables increase the degrees of freedom of a dynamical system and as such, complexity increases. Finding the collective variables that capture the dynamics of a system is an important scientific challenge.

This dynamical systems approach was first introduced into the field of human behaviour by Kugler *et al.* (1980) and Kelso (1984) through well-known within person experiments on dual-limb coordination, later extended to between person experiments on lower leg swinging (Schmidt *et al.*, 1990), swinging pendulums (Schmidt *et al.*, 1993; Schmidt & Turvey, 1994) and rocking chair exercise (Richardson *et al.*, 2007). These studies share two important characteristics, namely that coordination emerged spontaneously as a result of interacting subsystems and that coordination patterns preferably settled into two modes, either in-phase or

anti-phase, mathematically conceptualized as two coupled oscillators, i.e. the HKB-model (Haken *et al.*, 1985). This coupled oscillator paradigm has found its way into sports performance literature, especially in individual sports like squash (McGarry & Franks, 1996; McGarry *et al.*, 1999) and tennis (Lames, 2006; Palut & Zanone, 2005). From these studies, it was concluded that both squash and tennis players behave like coupled oscillators and can therefore be considered a dynamical system.

Ball team sports like soccer are much more complex, primarily due to the invasive nature and the number of players. Gréhaigne *et al.* (1997) and McGarry *et al.* (2002) proposed that interactions between soccer players give rise to team behaviour and may be described as a dynamical system. Because positional information of players over time may reflect interactions between players, it has the potential to describe the dynamics of training and matches. Analyses have primarily focused on collective variables in discrete 1 vs. 1 training or match situations. Araújo *et al.* (2004) analyzed 1 vs. 1 situations in basketball. They calculated the median point of the distance between the players to the goal area and the interpersonal distance between attacker and defender, with the former being the collective variable and the latter being a control parameter.

Results showed that the attacker fluctuates the direction of attack in front of the defender and the defender countermoves in order to maintain stability. Superiority of the attacker results in dribbling past the defender, whereas superiority of the defender preserves the initial stability. From these data, Araújo *et al.* (2004) concluded that features of dynamical systems were established in a 1 vs. 1 attacker-defender dyad in basketball. Recently, this was confirmed in a study of Bourbousson *et al.* (2010a) on intra- and inter-couplings among player dyads in basketball.

Passos *et al.* (2006, 2008) performed similar analyses in attacker-defender dyads in rugby. They showed that next to interpersonal distance, relative velocity between the attacker and defender was an important control parameter. They also demonstrated that these variables are intertwined, because at a given interpersonal distance a high relative speed means superiority for the attacker whereas low relative velocity means superiority for the defender. One implication for sports practice is that players must be encouraged to explore the relative speed that is required to pass a defender.

However, invasion sports include more than discrete, short term 1 vs. 1 situations. Thus, to explore tactical behaviour of interacting

players or tactical strategies of teams, there is a need for collective variables that capture the dynamics of ball team sports during full-sized matches and small-sided games during training, as representation of match sub-phases of full-sized matches (Davids *et al.*, 2007).

### *Outline of the thesis*

In the current thesis, an innovative approach to match analysis is adopted and positional data from small-sided training games and elite-standard full-sized soccer matches is used to calculate geometrical configurations that represent tactical concepts in soccer. As such, the main goals of this thesis are to introduce new performance measures grounded in positional data, to evaluate them in small-sided training games and full-sized matches and to examine if task manipulations constrain interactive team behaviour. Because parts of the data collection took place in a training setting with an innovative tracking technology, the final aim was to establish the accuracy and validity of this tracking system. For these purposes, a series of experimental and observational studies involving youth, adult and (non) elite-standard soccer players was performed.

In chapter two the accuracy and validity of an electronic tracking

system is presented. Positional data obtained with this technology is used to calculate centroid position and surface area. These measures are the core of this thesis and will be introduced in chapter three. Detailed information on calculations and experimental data is provided there. Chapter four reports data of a full-sized elite-standard soccer match. Based on the centroid positions of two teams, inter-team distances are calculated and the aim is to predict critical match periods from periods of high variability in inter-team distances. Chapter five aims to identify how and if changes in pitch dimensions act as a constraint on pattern formation and interactive behaviour in small-sided soccer games. Hereto, length, width and length-width manipulations are applied. Finally, the inter-team distances and variability thereof are analyzed across a series of elite-standard soccer matches in chapter six. The current thesis concludes with a general discussion of the key findings, a discussion of the limitations, recommendations for future research, conclusions, theoretical implications and practical implications.

## REFERENCES

1. > Araújo, D., Davids, K., Bennett, S.J., Button, C., & Chapman, G. (2004). Emergence of sport skills under constraints. In A.M. Williams & N.J. Hodges (Eds.), *Skill Acquisition in Sport: Research, Theory and Practice* (pp. 409-433). London: Routledge, Taylor & Francis.
2. > Barris, S. & Button, C. (2008). A review of vision-based motion analysis in sport. *Sports Medicine*, 38, 1025-1043.
3. > Bourbousson, J., Sève, C., & McGarry, T. (2010a). Space-time coordination dynamics in basketball: Part 1. Intra- and inter-couplings among player dyads. *Journal of Sports Sciences*, 28, 339-347.
4. > Bourbousson, J., Sève, C., & McGarry, T. (2010b). Space-time coordination dynamics in basketball: Part 2. The interaction between the two teams. *Journal of Sports Sciences*, 28, 349-358.
5. > Borrie, A., Jonsson, G.K. & Magnusson, M.S. (2002). Temporal pattern analysis and its applicability in sport: an explanation and exemplar data. *Journal of Sports Sciences*, 20, 845-852.
6. > Carling, C., Reilly, T. & Williams, A.M. (2009). Performance assessment for field sports; Match analysis, chapter 4, pp. 70-102. London: Routledge.
7. > Carling, C., Bloomfield, J., Nelsen, L. & Reilly, T. (2008). The role of motion analysis in elite soccer: Contemporary performance measurement techniques and work rate data. *Sports Medicine*, 38, 839-62.
8. > Carling, C., Williams, A.M., & Reilly, T. (2005). *Handbook of soccer match analysis: A systematic approach to improving performance*. London: Routledge.
9. > Coutts, A.J. & Duffield, R. (2010). Validity and reliability of GPS devices for measuring movement demands of team sports. *Journal of Science and Medicine in Sport*, 13(1), 133-135.
10. > Davids, K., Araújo, D., Button, C., & Renshaw, I. (2007). Degenerate brains, indeterminate behavior and representative tasks: Implications for experimental design in sport psychology research. In G. Tenenbaum & B. Eklund (Eds.), *Handbook of Sport Psychology* (pp. 224-244). Hoboken, NJ: John Wiley.
11. > Di Salvo, V., Collins, A., McNeill, B. & Cardinale, M. (2006). Validation of Prozone: a new video-based performance analysis system. *International Journal of Performance Analysis in Sport*, 6, 108-119.
12. > Dobson, B.P. & Keogh, J.W.L. (2007) Methodological issues for the application of time-motion analysis research. *Strength and Conditioning Journal*, 29, 48-55.
13. > Duch, J., Waitzman, J.S. & Amaral, L.A.N. (2010). Quantifying the performance of individual players in a team activity. *PLoS ONE* 5(6): e10937.
14. > Edgcomb, S.J. & Nornton, K.I. (2006). Comparison of global positioning and computer-based tracking systems for measuring player movement distance during Australian football. *Journal of Science and Medicine in Sport*, 9, 25-32.
15. > Gréhaigne, J.F., Bouthier, D., & David, B. (1997). Dynamic-system analysis of opponent relationships in collective actions in soccer. *Journal of Sports Sciences*, 15, 137-149.
16. > Haken, H., Kelso, J.A.S., & Bunz, H. (1985). A theoretical model of phase-transitions in human hand movements. *Biological Cybernetics*, 51, 347-356.
17. > Hill-Haas, S.V., Dawson, B., Impellizzeri, F.M. & Coutts, A.J. Physiology of small-sided games training in football. A systematic review. *Sports Medicine*, 2011, 41(3): 199-220.
18. > Hughes, M., & Franks, I.M. (2004). Notational analysis – a review of literature. In: M. Hughes & I.M. Franks (Eds.), *Notational Analysis of Sport. Systems for better coaching and performance in sport*, chapter 4, pp. 59-106. New York: Routledge.
19. > Kelso, J.A.S. (1984). Phase-transitions and critical behavior in human bimanual coordination. *American Journal of Physiology*, 246, 1000-1004.
20. > Kugler, P.N., Kelso, J.A.S., & Turvey, M.T. (1980). On the concept of coordinated structures as dissipative structures. In: *Theoretical lines of convergence*. In G.Stelmach & J. Requin (Eds.), *Tutorials in motor behavior* (pp. 3-45). Amsterdam: North Holland.
21. > Lames, M. (2006). Modelling the interaction in game sports - Relative phase and moving correlations. *Journal of Sports Science and Medicine*, 5, 556-560.
22. > Lames, M., Erdmann, J., & Walter, F. (2008). Oscillations in football - order and disorder in spatial interactions between the two teams. *Book of abstracts of the 2nd ICCSS*, 114-115.
23. > MacLeod, H., Morris, J., Nevill, A. & Sunderland, C. (2009). The validity of a non-differential global positioning system for assessing player movement patterns in field hockey. *Journal of Sports Sciences*, 27(2), 121-128.



- Maslovat, D., Franks, I.M. (2008). *The need for feedback*. In: M. Hughes & I.M. Franks (Eds.), *The Essentials of Performance Analysis: An Introduction*, chapter 1, pp. 1-7. London: Routledge. < 24.
- McGarry, T. (2005). *Soccer as a dynamical system: Some theoretical considerations*. In T. Reilly & D. Araújo (Eds.), *Science and Football V* (pp. 561-570). London: Routledge. < 25.
- McGarry, T., Anderson, D.I., Wallace, S.A., Hughes, M.D., & Franks, I.M. (2002). *Sport competition as a dynamical self-organizing system*. *Journal of Sports Sciences*, 20, 771-781. < 26.
- McGarry, T. & Franks, I.M. (1996). *Development, application, and limitation of a stochastic Markov model in explaining championship squash performance*. *Research Quarterly for Exercise and Sport*, 67, 406-415. < 27.
- McGarry, T., Khan, M.A., & Franks, I.M. (1999). *On the presence and absence of behavioural traits in sport: An example from championship squash match-play*. *Journal of Sports Sciences*, 17, 297-311. < 28.
- Palut, Y. & Zanone, P.G. (2005). *A dynamical analysis of tennis: Concepts and data*. *Journal of Sports Sciences*, 23, 1021-1032. < 29.
- Passos, P., Araújo, D., Davids, K., Gouveia, L., Milho, J., & Serpa, S. (2008). *Information-governing dynamics of attacker-defender interactions in youth rugby union*. *Journal of Sports Sciences*, 26, 1421-1429. < 30.
- Passos, P., Araújo, D., Davids, K., Gouveia, L., & Serpa, S. (2006). *Interpersonal dynamics in sport: The role of artificial neural networks and 3-D analysis*. *Behavior Research Methods*, 38(4), 683-691. < 31.
- Passos, P., Davids, K., Araújo, D., Paz, N., Minguéns, J. & Mendes, J. (2011). *Networks as a novel tool for studying team ball sports as complex social system*. *Journal of Science and Medicine in Sport*, 14, 170-176. < 32.
- Randers, M.B., Mujika, I., Hewitt, A., Santisteban, J., Bischoff, R., Solano, R., Zubillaga, A., Peltola, E., Krstrup, P. & Mohr, M. (2010). *Application of four different football match analysis systems: A comparative study*. *Journal of Sports Sciences*, 28(2), 171-182. < 33.
- Reed, D. & Hughes, M. (2006). *An exploration of team sport as a dynamical system*. *International Journal of Performance Analysis in Sport*, 6, 114-125. < 34.
- Richardson, M.J., Marsh, K.L., Isenhower, R.W., Goodman, J.R.L., & Schmidt, R.C. (2007). *Rocking together: Dynamics of intentional and unintentional interpersonal coordination*. *Human Movement Science*, 26, 867-891. < 35.
- Schmidt, R.C., Carello, C., & Turvey, M.T. (1990). *Phase-transitions and critical fluctuations in the visual coordination of rhythmic movements between people*. *Journal of Experimental Psychology-Human Perception and Performance*, 16, 227-247. < 36.
- Schmidt, R.C., Shaw, B.K., & Turvey, M.T. (1993). *Coupling dynamics in interlimb coordination*. *Journal of Experimental Psychology-Human Perception and Performance*, 19, 397-415. < 37.
- Schmidt, R.C. & Turvey, M.T. (1994). *Phase-entrainment dynamics of visually coupled rhythmic movements*. *Biological Cybernetics*, 70, 369-376 < 38.
- Serrano, J. & Fernandes, O. (2011). *Reliability of a new method to analyse and to quantify athletes' displacement*. *Portuguese Journal of Sport Sciences*, 11(suppl. 2), 935-936 < 39.
- Silva, J., Araújo, D., Duarte, R., Parola, A., Lima, J. & Nabais, F. (2011). *A tracking system using markers for association football*. *Football Science; book of abstracts of the 7th World Congress on Science & Football*, 8(suppl. 1), 103. < 40.
- Stolen, T., Chamari, K., Castagna, C., & Wisloff, U. (2005). *Physiology of soccer - An update*. *Sports Medicine*, 35, 501-536. < 41.
- Tijdink, H., Frencken, W.G.P. & Lemmink, K.A.P.M. (2011). *Versnellingen en vertragingen in het zaalvoetbal*. *Sportgericht* 65(5), 38-42. < 42.
- Varley, M.C., Fairweather, I.H. & Aughey, R. J. (2012) *Validity and reliability of GPS for measuring instantaneous velocity during acceleration, deceleration, and constant motion*. *Journal of Sports Sciences*, 30(2), 121-127. < 43.





# SOCCKER-SPECIFIC ACCURACY AND VALIDITY OF THE LOCAL POSITION MEASUREMENT (LPM) SYSTEM

Wouter G.P. Frencken <sup>1</sup>  
Koen A.P.M. Lemmink <sup>1,2</sup>  
Nico J. Delleman <sup>3</sup>

*1 University Medical Center Groningen,  
University of Groningen  
Center for Human Movement Sciences  
Groningen  
The Netherlands*

*2 Hanze University of Applied Sciences  
School of Sports Studies  
Groningen  
The Netherlands*

*3 InnoSportNL  
Arnhem  
The Netherlands*

## Abstract

Limited data is available on accuracy and validity of video-based, GPS and electronic tracking systems, particularly with reference to curved courses and short high intensity running activities. The main goal of this study was to assess soccer-specific accuracy and validity of the radio-frequency based local position measurement (LPM) system (1000 Hz) for measuring distance and speed during walking and sprinting. Three males walked and sprinted 4 soccer-specific courses 10 times each. Distance and speed recorded by LPM were compared to actual distance and speed measured by measuring tape and timing gates. In addition, accuracy was assessed. The static accuracy (SD of the mean) is 1 cm for devices put on the pitch and 2-3 cm when worn by participants. LPM underestimates actual distance (mean difference at most -1.6 %). Coefficient of variation becomes larger at higher speed and increased turning angle. With regard to speed, validity correlations are high (range: 0.71 - 0.97). The LPM speed is significantly and systematically lower, although absolute and relative differences are small, between  $-0.1 \text{ km h}^{-1}$  (-1.3 %) and  $-0.6 \text{ km h}^{-1}$  (-3.9 %). The typical error of the estimate increases with increased speed, but does not increase with increased turning angle. Because the reported differences are small, we conclude that the LPM-system produces highly accurate position and speed data in static and dynamic conditions and is a valid tool for player tracking in soccer and ball team sports in general.

*In: Journal of Science and  
Medicine in Sport,  
2010, 13, 641-645*

**Player tracking,  
Match analysis,  
Training analysis,  
Team sports,  
Performance analysis**

# INTRODUCTION

In sports performance analysis, many tracking technologies are used to record player positions (see Carling *et al.*, 2009 for a recent overview of technologies). Technological innovations of data acquisition systems underlie improvements with respect to type of data and data quality that become available. The majority of the data acquisition systems are video-based. However, GPS and electronic tracking systems are becoming increasingly popular. Each of these technologies have their well-described practical advantages and disadvantages when it comes to evaluating athletes' physical performance (Barris & Button, 2008; Carling *et al.*, 2008; Duncan *et al.*, 2009; Dobson & Keogh, 2007).

Although a wealth of data in sports science is obtained through various tracking technologies, limited data is available on accuracy, validity and reliability of these technologies. The studies that have investigated validity and reliability have proven that techniques like video-tracking (Edgecomb & Norton, 2006; Di Salvo *et al.*, 2006; Duthie *et al.*, 2003) and GPS-tracking (Coutts & Duffield, 2010; MacLeod *et al.*, 2009; Portas *et al.*, 2007) are sufficiently accurate and reliable for the evaluation and estimation of covered distance and speed in general. However, these studies also demonstrated important shortcomings of video-tracking (Edgecomb & Norton, 2006) and GPS (Barbero-Álvarez *et al.*, 2010; Coutts & Duffield, 2010; Portas *et al.*, 2007) when short sprints (<1 s), high intensity runs and turning movements are involved. The primary cause that has been denoted for the decreased accuracy and validity of these activities is the low sampling rate. It has therefore been suggested that an increased sampling frequency would improve both accuracy and reliability of the high intensity activities (Edgecomb & Norton, 2006; Coutts & Duffield, 2008; Duffield *et al.*, 2010).

Another important shortcoming of previous validity studies is the experimental protocol. The protocols consist primarily of long straight courses or continuous circular paths. Both do not adequately reflect player runs in soccer, because, players accelerate, decelerate and change direction continuously. Furthermore, these studies have only assessed athletes while moving. In terms of precision of measurement, it is also important to evaluate accuracy in static conditions (Duncan *et al.*, 2009; Townshend *et al.*, 2008). Finally, previous studies have not assessed whether validity is affected by increased speed or turning angles, but validated technologies over a wide speed range and courses containing no turns.

So, several factors that may influence the accuracy and validity of a tracking system have not yet been evaluated. In the current study, we validate a high frequency (1000 Hz) radio-frequency based technology, the local position measurement (LPM) system (Inmotio Object Tracking BV, Amsterdam, the Netherlands), in a soccer-specific setting. We particularly aim at those issues that other studies did not include. So, the main goal of this study is to assess soccer-specific accuracy and validity of the LPM-system for measuring distance and speed during walking and sprinting. In addition, we aim to clarify to what extent turns affect accuracy and validity.

## Methods

Three males (age:  $25 \pm 2$  y, height:  $1.87 \pm 0.05$  m, weight:  $81 \pm 2$  kg) participated in this study. Participants wore a vest containing a transponder located on the back that was connected to two antennas, one on top of each shoulder. A further nineteen transponders were put randomly across the pitch, to match the total number of 22 players in an official soccer match. The antennas received radio frequency signals, transmitted by the main base station. This signal was tagged, transmitted back to the ten base stations surrounding the pitch and transported by means of glass fiber technology to a server and computer in the command room where data was stored (Stelzer *et al.*, 2004). Average position of the antenna's was calculated (cm) based on timing differences (Stelzer *et al.*, 2004). Due to the reciprocal relationship between the sampling frequency and the number of transponders, the sampling frequency is 45 Hz ( $1000/22$ ).

The experiment consisted of static and dynamic measurements. First, three measurements of 20 s ( $45 \times 20 = 900$  samples) were performed to assess accuracy of motionless transponders ( $N = 22$ ), when on the pitch ( $N = 19$ ) and when worn by participants ( $N = 3$ ). Participants were instructed not to move. In dynamic conditions,

participants walked and sprinted four soccer-specific courses (figure 1). These courses were designed considering the most frequently occurring directional changes (Bloomfield *et al.*, 2007), sprint lengths and sprint times (Bishop *et al.*, 2001) in soccer. The start, turning points and end of each course were marked by a cone. The distance between the cones was measured by means of a measuring tape. Timing gates were placed at the start and end of the course. The starting position of each trial was 3 m in front of the first timing gate. Participants had to walk and sprint each trajectory 10 times at preferred speed and were instructed to follow the course marked by the cones as closely as possible. The procedures used in this study were in accordance with the guidelines of the Medical Ethical Committee of the Medical Faculty of the University Medical Center Groningen, University of Groningen, the Netherlands.

In the static condition, the accuracy of the static measurements was assessed by calculating mean distance (cm)  $\pm$  SD of each sample to the average position of the transponder (Townshend *et al.*, 2008). For all dynamic conditions, distance (cm) and average speed ( $\text{km h}^{-1}$ ) of LPM values (provided by the LPM-system) and actual values (measuring tape and timing gates) were calculated for all four courses, for both walking and sprinting. For distance covered, descriptive statistics and a coefficient of variation (standard

deviation expressed as a percentage of the mean) were calculated. The average speed was validated by linear regression using the spreadsheet developed by Hopkins (Hopkins, 2009). Absolute and relative (%) differences between the two measures were calculated, along with the raw typical error of the estimate (TEE) and the typical error of the estimate expressed as a coefficient of variation (TEE%). For all variables but the relative difference, 95 % confidence limits were calculated. The absolute difference between actual speed and LPM speed was considered statistically significant if zero was not in the 95 % confidence interval. Data were checked for heteroscedasticity by plotting residuals versus predicted values.

## Results

In static conditions, the average positional error of the transponders on the pitch is  $1 \pm 0$  cm for the three respective measurements. During the first measurement, one of nineteen transponders had 0 cm positional error. During the second measurement, one transponder had an average positional error of 2 cm. When worn by the participants, the average positional error is  $2 \pm 1$  cm,  $2 \pm 1$  cm and  $3 \pm 1$  cm for the three measurements.

In dynamic conditions, LPM underestimates actual distance for all courses, apart from the 500 cm straight (table 1). The mean difference between actual distance and LPM distance increases with course length and turning angle. This is also reflected by the CV%, which increases with increased course length. However, for both walking and sprinting the relative increase in CV% is larger with a sharper turning angle, 45° and 90° respectively.

Table 2 shows that the mean absolute speed differences are approximately  $-0.1$  km h<sup>-1</sup> and  $-0.4$  km h<sup>-1</sup> for respectively walking and sprinting. The negative values of the mean speed difference indicate that LPM speed is consistently and significantly lower compared to actual speed. The TEE% is higher in the sprinting condition compared to the walking condition for all courses apart from the 5 m straight. Pearson correlation coefficients are high,

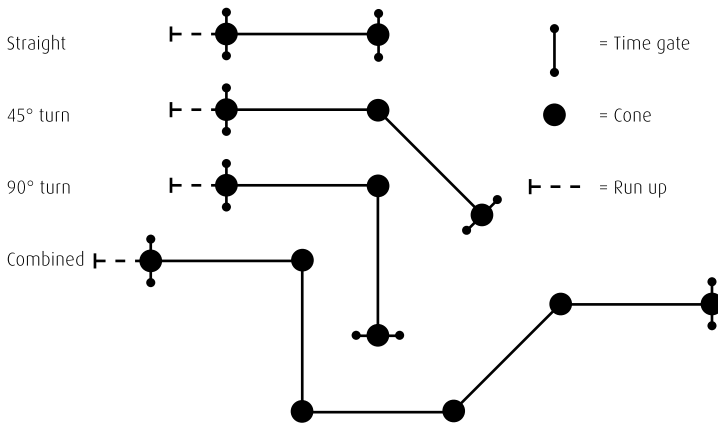

Figure 1. Schematic representation of soccer-specific courses, the 5m straight, 10 m 45° turn, 10m 90° turn and the 25 m combined course. Length between adjacent cones is 5 m.

between 0.71 and 0.97. The data did not show heteroscedasticity.

### Discussion

The aim of this study was to investigate accuracy and validity of the local position measurement (LPM) system in soccer-specific conditions for walking and sprinting. Our results demonstrated high static accuracy. The average positional error in three subsequent measurements was 1 cm for the transponders on the pitch and 2 or 3 cm for the transponders worn by the participants. The increase in positional error is most likely due to postural sway. A value of 5 mm has been reported for the sway of the centre of mass in two-legged stance under laboratory circumstances on a force plate (Hof *et al.*, 2005). It can be argued that the postural sway is larger in an outdoor field setting with the athlete facing the elements with postural sway being measured at the shoulders.

In dynamic conditions, we firstly compared the distance walked and distance sprinted as recorded by the LPM-system with the fixed distance on various courses. Results show that the LPM-system underestimates the actual distance, but it is well under 1.6 % on average (table 1). So, the magnitude of the difference is smaller compared to video-tracking (4.8 % on average) and GPS (5.8 % on average) (Coutts & Duffield, 2010; Edgecomb &

Table 1. Descriptive statistics of LPM-distance of all courses for walking and sprinting (30 trials per course). Data presented in cm.

Course	Course Length (cm)	Difference			Mean difference	
		Mean ± SD	Min - Max	95% CI	as a %	SD as CV%
<i>WALKING</i>						
Straight	500	1 ± 2	-2 - 5	0 - 2	0.2	0.4
45° turn	1000	-8 ± 6	-9 - 4	-10 - -6	-0.8	0.6
90° turn	1000	-16 ± 10	-33 - 6	-20 - -12	-1.6	1.0
Combined	2500	-29 ± 27	-77 - 26	-40 - -19	-1.2	1.1
<i>SPRINTING</i>						
Straight	500	0 ± 3	-6 - 10	-1 - 1	0.0	0.6
45° turn	1000	-6 ± 9	-25 - 10	-9 - -2	-0.6	0.9
90° turn	1000	-16 ± 20	-48 - 25	-24 - -9	-1.6	2.0
Combined	2500	-2 ± 42	-63 - 104	-14 - 18	-0.1	1.7

Table 2. Comparison of average actual speed (km h<sup>-1</sup>) and average LPM speed (km h<sup>-1</sup>) over 30 trials for walking and sprinting four soccer-specific courses.

Course	Actual	LPM	Difference		TEE		TEE %		r
	Mean ± SD	Mean ± SD	Mean ± SD	95% CI	Raw 95% CI	CV% 95% CI			
<i>WALKING</i>									
Straight	5.5 ± 0.3	5.3 ± 0.3	-0.2 ± 0.2	-0.2 - -0.1	0.2 0.2 - 0.3	3.9 3.0 - 5.2		0.80	
45° turn	5.7 ± 0.1	5.6 ± 0.2	-0.1 ± 0.2	-0.2 - -0.0	0.1 0.1 - 0.1	1.6 1.3 - 2.2		0.71	
90° turn	5.5 ± 0.2	5.4 ± 0.3	-0.1 ± 0.1	-0.2 - -0.1	0.1 0.1 - 0.1	1.4 1.1 - 1.9		0.92	
Combined	5.3 ± 0.3	5.1 ± 0.3	-0.1 ± 0.1	-0.1 - -0.1	0.1 0.1 - 0.1	1.4 1.1 - 1.8		0.97	
<i>SPRINTING</i>									
Straight	16.6 ± 1.2	16.0 ± 1.2	-0.6 ± 0.5	-0.8 - -0.5	0.5 0.4 - 0.7	3.2 2.5 - 4.3		0.91	
45° turn	17.4 ± 0.9	16.9 ± 0.8	-0.5 ± 0.4	-0.7 - -0.4	0.4 0.3 - 0.5	2.2 1.7 - 2.9		0.90	
90° turn	14.9 ± 0.7	14.6 ± 0.8	-0.4 ± 0.4	-0.5 - -0.2	0.4 0.3 - 0.5	2.6 2.0 - 3.5		0.86	
Combined	15.3 ± 0.7	15.2 ± 0.5	-0.2 ± 0.3	-0.3 - -0.1	0.3 0.2 - 0.4	1.8 1.5 - 2.5		0.93	

Norton, 2006). In previous literature, overestimates of true distance have been reported in video-tracking and GPS (Coutts & Duffield, 2010; Edgecomb & Norton, 2006) as well as underestimates for GPS devices (Coutts & Duffield, 2010). The design of the validation protocols is the most likely cause for this. In our study, the main underestimation is found in the course containing the 90° turn. This is also the course, where in both speed conditions it is most difficult for the participants to follow the marked course as closely as possible, meaning they cover less distance because turns are cut off. So, because corners are cut, distance covered by participants is likely less than official course length, partly explaining the underestimation by LPM. Therefore, this results in a bigger variation of covered distance for that course, which is reflected by highest CV% for this course (table 1). So, the main finding in regard to distance is that LPM-system accurately records distance, although it slightly underestimates actual distance. Furthermore, variation becomes larger at higher speed and increased turning angle.

Secondly, we compared average course speed (LPM) to the average actual course speed. Although correlations are high ( $0.71 < r < 0.97$ ), our results point at a systematic error since the average LPM speed is significantly and systematically lower compared to actual speed for all courses. Nevertheless, both absolute and relative differences are

small, respectively between  $-0.1 \text{ km h}^{-1}$  (-1.3 %) and  $-0.6 \text{ km h}^{-1}$  (-3.9 %). These absolute differences are smaller than reported in previous literature on GPS (Witte & Wilson, 2005). However, correlations between average LPM speed and average actual speed in this study are generally lower in comparison to previous literature (Di Salvo *et al.*, 2007; Edgecomb & Norton, 2006; MacLeod *et al.*, 2009). This is due to the homogeneity of our sample, because the speed range is approximately  $0.6 \text{ km h}^{-1}$  for all courses in the walking condition and approximately  $1.7 \text{ km h}^{-1}$  in the sprinting condition. The wider range of speed values in the sprinting condition would then on average yield higher correlations compared to the walking condition. This phenomenon is also present in our data (table 2).

Finally, the TEE clearly shows that the magnitude of the error increases with increased speed (table 2). During walking, the TEE is fairly stable judged by the confidence intervals, whereas more variation is present in the sprinting condition. Furthermore, TEE does not increase with increased turning angle. There is even a trend towards a better estimation of average course speed of the LPM-system with an increased number of turns. In terms of the TEE%, this trend is only present in the walking condition, which is an indication of more accurate tracking at lower speeds. So, the first main finding with regard to speed is that the LPM-system systemati-

cally underestimates actual speed, although the differences are small. Secondly, we found that the TEE increases with increased speed, but does not increase with increased turning angles.

Taken all together, we argue that the LPM-system is an accurate and valid tool for measuring distance and speed in soccer. It must be noted that the small differences we demonstrated in this study, are dependent on the current criterion measure (i.e. timing gates and measuring tape), as currently no real gold standard is available for recording distance and speed of curved courses in soccer. So, whether our reported differences are meaningful, depends on the goal of future studies. Nevertheless, we argue that because of the accuracy, small differences reported, high sampling frequency and the ability to use it both indoors and outdoors, LPM opens up new applications and types of analysis in soccer that not yet have been possible, e.g. advanced time-motion analyses or analyses of complex spatial-temporal patterns. This also implies that our findings not only apply to soccer, but extend to many other ball team sports and individual sports. In team sports with less active players, the advantage of high sampling frequency becomes larger. Also, individual players can be equipped with more devices for specific purposes.

To conclude, we have shown that the LPM-system produces highly accurate position and speed data in static and dynamic conditions. In addition, we have provided further insight in the effect of sharp turns on validity measurements during walking and sprinting short courses. Finally, we argued that technologies with high sampling frequencies open up new applications and types of analyses in sports science.

### *Practical implications*

The LPM-system is a valid tool to record positions of athletes in outdoor and indoor field settings. This opens up new avenues for sports scientists.

The LPM-system provides accurate data in static and dynamic conditions at various speeds.

Multiplayer testing in training or matches with high sampling rate is possible.

&lt;

&lt;

&lt;

### *Acknowledgements*

*We would like to thank Frans Lefeber, Jorrit van der Plaats and Michel Brink for assisting during data acquisition. No external financial support was received for this study.*

## REFERENCES

1. > Barbero-Álvarez, J.C., Coutts, A.J., Granda, J., Barbero-Álvarez, V. & Castagna, C. (2010). The validity and reliability of a global positioning satellite system device to assess speed and repeated sprint ability (RSA) in athletes. *Journal of Science and Medicine in Sport*, 13(2), 232-235.
2. > Barris, S. & Button, C. (2008). A review of vision-based motion analysis in sport. *Sports Medicine*, 38, 1025-1043.
3. > Bloomfield, J., Polman, R. & O'Donoghue, P. (2007). Physical demands of different positions in FA Premier League soccer. *Journal of Sports Science and Medicine*, 6, 63-70.
4. > Bishop, D., Spencer, M., Duffield, R. & Lawrence, S. (2001). The validity of a repeated sprint ability test. *Journal of Science and Medicine in Sport*, 4, 19-29.
5. > Carling, C., Bloomfield, J., Nelsen, L. & Reilly, T. (2008). The role of motion analysis in elite soccer: contemporary performance measurement techniques and work rate data. *Sports Medicine*, 38, 839-62.
6. > Carling, C., Reilly, T. & Williams, A.M. (2009). *Performance assessment for field sports: Physiological, psychological and match notational assessment in practice*. London: Routledge, 2009.
7. > Coutts, A.J. & Duffield, R. (2010). Validity and reliability of GPS devices for measuring movement demands of team sports. *Journal of Science and Medicine in Sport*, 13(1), 133-135.
8. > Di Salvo, V., Collins, A., McNeill, B. & Cardinale, M. (2006). Validation of Prozone: A new video-based performance analysis system. *International Journal of Performance Analysis in Sport*, 6, 108-19.
9. > Duffield, R., Reid, M., Baker, J. & Spratford, W. (2010). Accuracy and reliability of GPS devices for measurement of movement patterns in confined spaces for court-based sports. *Journal of Science and Medicine in Sport*, 13(5), 523-525.
10. > Duncan, M.J., Badland, H.M. & Mummery, W.K. (2009). Applying GPS to enhance understanding of transport-related physical activity. *Journal of Science and Medicine in Sport*, 12(5), 549-556.
11. > Duthie, G., Pyne, D. & Hooper, S. (2003). The reliability of video based time motion analysis. *Journal of Human Movement Studies*, 44, 259-71.
12. > Dobson, B.P. & Keogh, J.W.L. (2007). Methodological issues for the application of time-motion analysis research. *Strength & Conditioning Journal*, 29, 48-55.
13. > Edgecomb, S.J. & Norton, K.I. (2006). Comparison of global positioning and computer-based tracking systems for measuring player movement distance during Australian Football. *Journal of Science and Medicine in Sport*, 9, 25-32.
14. > Hof, A.L., Gazendam, M.G.J. & Sinke, W.E. (2005). The condition for dynamic stability. *Journal of Biomechanics*, 38, 1-8.
15. > Hopkins, W. G. A new view of statistics. *Sportsci.org: Internet society for sport science*. Available at: <http://www.sportsci.org/resource/stats/valid.html>. Accessed 21 October 2009.
16. > MacLeod, H., Morris, J., Nevill, A. & Sunderland, C. (2009). The validity of a non-differential global positioning system for assessing player movement patterns in field hockey. *Journal of Sports Sciences*, 27, 121-8.
17. > Portas, M.J., Rush, C.J., Barnes, C.A. & Batterham, A.M. (2007). Method comparison of linear distance and velocity measurements with global positioning satellite (GPS) and the timing gate techniques. *Journal of Sports Science and Medicine*, 6(Suppl. 10), 7-8.
18. > Stelzer, A., Pourvoyeur, K. & Fischer, A. (2004). Concept and application of LPM-A novel 3-D local position measurement system. *IEEE Transactions on Microwave Theory and Technology*, 52, 2664-9.
19. > Townshend, A.D., Worringham, C.J. & Stewart, I.B. (2008). Assessment of speed and position during human locomotion using nondifferential GPS. *Medicine and Science of Sports and Exercise*, 40, 124-32.
20. > Witte, T.H. & Wilson, A.M. (2005). Accuracy of WAAS-enabled GPS for the determination of position and speed over ground. *Journal of Biomechanics*, 38, 1717-22.







# OSCILLATIONS OF CENTROID POSITION AND SURFACE AREA OF SOCCER TEAMS IN SMALL-SIDED GAMES

Wouter G.P. Frencken <sup>1</sup>  
Koen A.P.M. Lemmink <sup>1,2</sup>  
Nico J. Delleman <sup>3</sup>  
Chris Visscher <sup>1</sup>

*1 University Medical Center Groningen,  
University of Groningen  
Center for Human Movement Sciences  
Groningen  
The Netherlands*

*2 Hanze University of Applied Sciences  
School of Sports Studies  
Groningen  
The Netherlands*

*3 InnoSportNL  
Arnhem  
The Netherlands*

## Abstract

There is a need for a collective variable that captures the dynamics of team sports like soccer at match level. The centroid positions and surface areas of two soccer teams potentially describe the coordinated flow of attacking and defending in small-sided soccer games at team level. The aim of the present study was to identify an overall game pattern by establishing whether the proposed variables were linearly related between teams over the course of the game. In addition, we tried to identify patterns in the build-up of goals. A positive linear relation and a negative linear relation were hypothesized for the centroid positions and surface areas respectively. Finally, we hypothesized that deviations from these patterns are present in the build-up of goals. Ten young male elite soccer players (mean age 17.3,  $s = 0.7$ ) played three small-sided soccer games (4-a-side) of 8 minutes as part of their regular training routine. An innovative player tracking system, local position measurement (LPM), was used for obtaining player positions at 45 Hz per player. Pearson correlation coefficients were calculated to investigate the proposed linear relation of the key variables. Correlation coefficients indicate a strong positive linear relation during a whole game for the centroid position in all three games, with the strongest relation for the forward-backward direction ( $r > 0.94$ ). For 10 out of 19 goals a crossing of the centroids in this direction can be seen. No negative linear relation was found for surface area ( $-0.01 < r < 0.07$ ). From this study, we concluded that over the course of a whole small-sided game, the forward-backward motion of the centroids was most strongly linearly related. Furthermore, goals show a specific pattern in the forward-backward motion of the centroid. Therefore, surface area and particularly centroid position may provide a sound basis for a collective variable that captures the dynamics of attacking and defending in soccer at team level. Future research should develop these ideas further.

*In: European Journal of Sport Science, 2011, 4, 215-223.*

**Patterns of play,  
Tactics,  
Goals,  
Performance  
analysis,  
Local position  
measurement (LPM),  
Correlations**

# INTRODUCTION

In recent years, technological developments have led to new methods for performance analysis in ball team sports, e.g. field hockey, basketball, soccer (Carling *et al.*, 2005; Carling *et al.*, 2008). These developments also allow for detailed registration of positional data of athletes. In both notational analysis (Hughes & Bartlett, 2002) and time-motion analysis (Drust *et al.*, 2007; Stolen *et al.*, 2005), positional data of different type is used to refine the analyses. However, accurate and continuous recording of individual player positions on the pitch also allows for analysis of tactics and patterns of play in sports contests.

The dynamical systems approach has shown to be useful for understanding spatial-temporal patterns in both individual and team sports (Frencken & Lemmink, 2008; Gréhaigne *et al.*, 1997; McGarry *et al.*, 1999; McGarry *et al.*, 2002; McGarry, 2005; Palut & Zanone, 2005; Reed & Hughes, 2006). This dynamical systems approach was first introduced into the field of human behaviour by Kugler *et al.* (1980) and followed up upon by Kelso (1984) through a well known experiment on dual-limb coordination showing inphase and antiphase coupling of the limbs. Mathematically, this was conceptualized as a model of two coupled oscillators, i.e. the HKB-model (Haken *et al.*, 1985). This coupled oscillator paradigm has been extended from within person coordination to between person coordination in experiments on lower leg swinging (Schmidt *et al.*, 1990), swinging pendulums (Schmidt *et al.*, 1993; Schmidt & Turvey, 1994), rocking chair exercise (Richardson *et al.*, 2007) and also sports (e.g. McGarry *et al.*, 2002; Palut & Zanone, 2005; Schmidt *et al.*, 1999).

It can be proposed that in sports contests, the interactions between the individual athletes, both within and between teams, give rise to the overall patterns that can be seen (McGarry *et al.*, 2002). Therefore, it can be argued that sports contests can be described as a dynamical system. Several studies have aimed to identify properties of dynamical systems recently, particularly in individual sports like squash (McGarry *et al.*, 1999; McGarry, 2005; McGarry & Franks, 1996) and tennis (Lames, 2006; Palut & Zanone, 2005), but also in team sports like basketball (Araújo *et al.*, 2004; Bourbousson *et al.*, 2010a; Bourbousson *et al.*, 2010b) and rugby (Passos *et al.*, 2006; Passos *et al.*, 2008).

McGarry *et al.* (1999) performed two experiments with elite squash players in which the distance of the players to the 'T-locus' was analyzed. It was shown that squash players oscillate around the 'T-locus' in a stable antiphase pattern. Furthermore, it was shown that some shots perturbed the rally, creating instability, which caused changes in the antiphase pattern. This resulted in either the end of the rally (a point scored) or recovery of the rally. Palut & Zanone (2005) performed similar analyses in tennis. They measured the lateral displacement of the athletes relative to the center position at the baseline and went one step beyond McGarry *et al.* (1999) by calculating relative phase. Data analysis showed



that the athletes oscillate around their locus, with slight deviations from perfect inphase and antiphase patterns. Similar results were found by Lames (2006). Next to that, Palut & Zanone (2005) found that the system can regain stability after perturbing shots. From these studies, it can be concluded that both squash and tennis players are coupled oscillators and can therefore be considered a dynamical system.

In team sports like basketball, rugby or soccer, similar analyses are more complex, primarily due to a higher number of players and the invasive nature of these sports. As a result, future research must provide more data to confirm if the coupled oscillator paradigm also holds for the many complex interactions of players in team sports, like conceptually has been put forward. Several researchers have conceptualized a soccer match in terms of dynamical systems (Gréhaigne *et al.*, 1997; McGarry *et al.*, 2002). However, these analyses have been fairly descriptive and focus primarily on collective variables in discrete 1 vs. 1 match situations. In this respect, Schmidt *et al.* (1999) suggested distance related measures as potential order and control parameters in basketball backdoor play. Araújo *et al.* (2004) and Passos *et al.* (2006; Passos *et al.*, 2008) followed up on this by analyzing similar measures in 1 vs. 1 situations in basketball and rugby respectively. In these studies, features of dynamical systems were established in 1 vs. 1 attacker-defender dyads. However, less collective variables are available that characterize the overall systems behaviour in team sports like soccer on match level, emphasizing the need for such variables. A clear repetitive pattern that is coordinated between two teams in invasive team sports is the rhythmic flow of attacking and defending. In that respect, Frencken & Lemmink (2008) proposed two variables that characterize the flow in small-sided soccer games: the centroid position and the surface area of a team. The centroid is the average position of the outfield players of one team and surface area is the covered space by the outfield players of one team. When attacking, the aim is to score a goal by going forward. Therefore the centroid of the attacking team moves forward. The defending team tries to prevent the attacking team from scoring by moving backward. Thus, its centroid will move backward. In addition, the attacking team opens up space by increasing distances between players and the defending team is closing down space by decreasing distances between players. Therefore, the surface area of the attacking team will be large, whereas the surface area of the defending team will be small. This is reversed when possession is lost. This reasoning implies that for a whole soccer game, the coordinated flow of attacking and defending is represented by a positive linear relation for centroid position and a negative linear relation for surface area.

It can be argued that this flow is also present in small-sided soccer games, because such games represent match sub-phases of full-sized matches (Davids *et al.*, 2007). Therefore, the level of analysis of small-sided games can be consid

ered a subsystem of the match system. However, the degree to which small-sided games actually represent full-sized matches depends on the constraints acting upon this system. Because they are generally considered a sub-phase of a regular match by coaches, they are frequently in daily training practice. In addition, benefits of this type of training are that it improves technical and physical abilities of soccer players (Hill-Haas *et al.*, 2008; Jones & Drust, 2007; Little & Williams, 2006; Tessitore *et al.*, 2006).

So, among the challenges for sport scientists is to put the conceptual model of soccer as a dynamical system into practice and understand its dynamics. This would improve our understanding of the complex nature of soccer and will result in clear-cut recommendations to coaches. The first step in this process is to identify one or more variables that potentially capture the flow of a soccer game, for which at team level centroid position and surface area have been proposed previously. In this study, we follow up on this by aiming to establish the proposed overall positive and negative linear associations between teams for these variables over the course of a game. Furthermore, we aim to identify patterns in the build-up to a goal by visual inspection of the data. We hypothesize a positive linear relation for the centroid positions and a negative linear relation for the surface areas of both teams.

## Materials & Methods

### Procedure

Ten young elite male soccer players (mean age 17.3 years,  $s = 0.7$ ) playing at the highest youth level in the Netherlands participated in this study. They played 3 small-sided soccer games of 8 minutes after a warm-up, interspersed by two-minute rest intervals. The 2 goalkeepers, 2 defenders, 4 midfielders and 2 attackers that participated in this study were randomly and equally distributed over the two teams. Games were played on a 28-36 m (width-length) pitch with regular FIFA-approved goals (7,32 x 2,44 m: width x height). No restrictions in game play were put in place for the outfield players. The offside rule was not applied. Goalkeepers were restricted to 2-touch play. All procedures were in accordance with the ethical standards of the Medical Faculty of the University Medical Center Groningen, University of Groningen.

### Data collection

Positional data was collected during a regular training session by means of the local position measurement (LPM) system (Inmotio Object Tracking BV, Amsterdam, the Netherlands). LPM is a radio frequency based technology that registers player positions ( $x, y, z$ ) over time (figure 1). Outdoors, ten base stations that transmit signals to the players and receive signals returning from the players surround the pitch. In addition, eight

video cameras are mounted onto the base stations. Both positional and video data were transported to the control room by means of glass fiber technology and stored on a video server and computer. There, positional and video data were synchronized.

In order to acquire positional data, players needed to wear a vest containing a transponder and two antennas that did not limit player movements. The transponder was located on the back and was connected to the antennas, one on top of each shoulder. The transponder added player identification information to the signal before

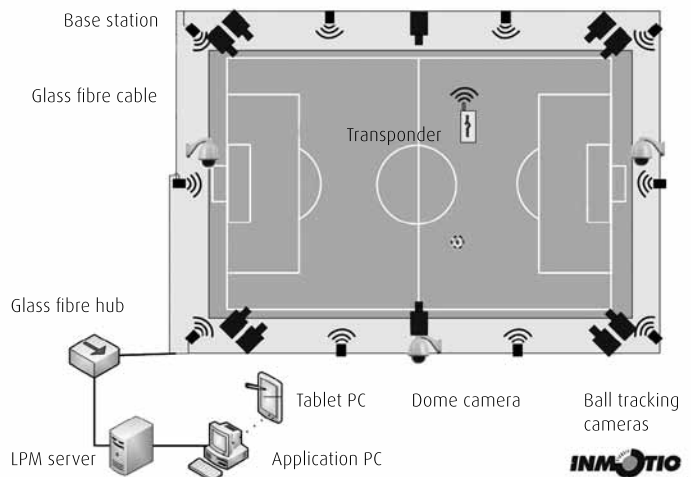

Figure 1. Schematic representation of the hardware setup of the local position measurement (LPM) system.

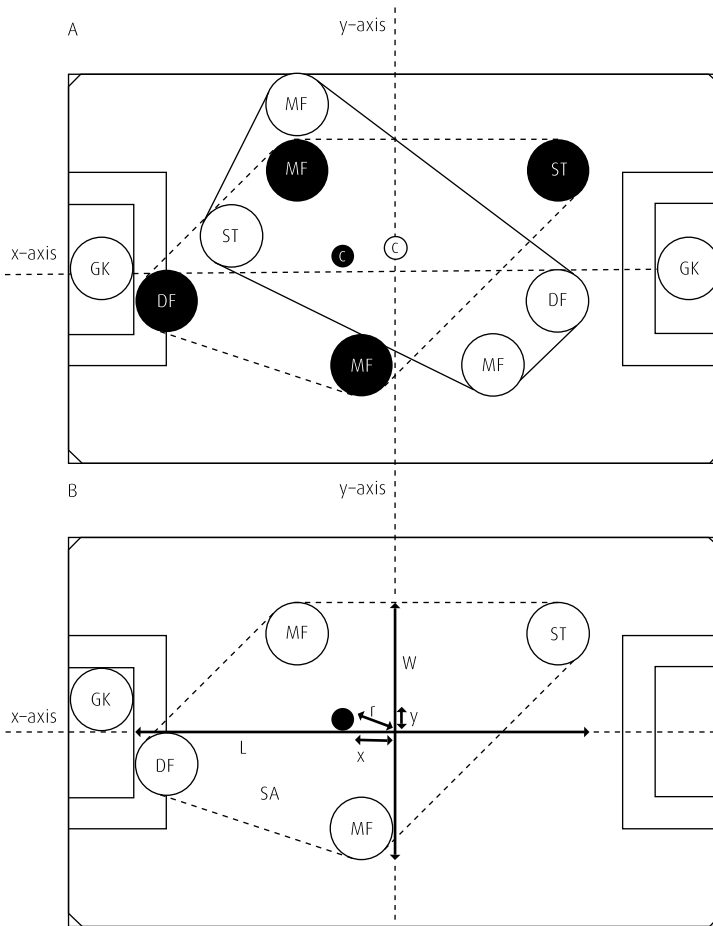

Figure 2. a) Player positions (GK =goal-keeper, DF =defender, MF =midfielder, ST =striker) and relation of centroid (c) and surface area (black and dashed line) measures for the two teams and b) calculation of measures for centroid position (black dot,  $r$  = radial distance,  $x$  =  $x$ - distance,  $y$  =  $y$ - distance) and surface area ( $L$  = length,  $W$  = width,  $SA$  = surface area).

transmitting the signal to the base stations. Player positions were calculated based on signal transmission times between base stations and antennas (Stelzer *et al.*, 2004). The sampling frequency for an individual player in this study was 45 Hz. Although not scientifically validated yet, precision of measurement is within 5 cm according to the manufacturer.

### Measures

The centroid and surface area relation between the teams is depicted in figure 2a. The centroid of a team was calculated as the mean position of all four outfield players of one team (figure 2b). From the centroid position of both teams three measures were derived. The  $x$ - distance (m) represents forward-backward displacement,  $y$ - distance (m) represents lateral displacement and radial distance (m), comprising both forward-backward and lateral displacement. These are the distances of the centroid position relative to the origin, which was defined as the centre point of the pitch.

For the surface areas of the teams, three measures were calculated: length (m), width (m) and surface area ( $m^2$ ) (figure 2b). Length was defined as the distance between the most backward and the most forward player ( $x$ - coordinate). Width was defined as the distance between the most lateral players on either side of the pitch ( $y$ - coordinate). The surface was



defined as total space covered by a team, referred to as the area within the convex hull. The convex hull was computed using a modified Graham algorithm (Graham, 1972). Firstly, a pivot point was determined. This was the player with the lowest y- value. If there are multiple, then the player with the highest x- value was the pivot point. Then, the angle from the pivot to each player was calculated. Players were sorted by angle and removed if not part of the convex hull. An arbitrary point within the convex hull, here the centroid, was taken to form a triangle with the player that was designated as pivot and one of the remaining players. Subsequently, the area was calculated by adding the triangles of consecutive points of the convex hull and the centroid. So in this study, three or four players determined the surface area. This process was repeated for both teams, for each sample.

*Statistical analysis*

Pearson correlation coefficients (*r*) were calculated for all centroid and surface area measures to establish a linear relation between the oscillations of both teams over the course of the small-sided games. A correlation coefficient of 1 indicates that the direction of the change is similar for both teams. A correlation of -1 represents a perfectly linear relation, but the direction of the change is opposite both teams. A correlation of zero indicates no linear relation.

When a goal was scored, the centroid and surface area data were visually inspected from the time that the possession was won by the team that scored until the goal was eventually scored. We compared the patterns in these parts of the data to the overall patterns that were found for the centroid positions and surface areas.

*Results*

*Centroid position and surface area*

Table 1 shows Pearson correlations for the time series of all centroid and surface area measures during the small-sided games. For the centroid measures, all forward-backward and lateral correlation coefficients are above 0.80. Correlation coefficients for the radial distance range from 0.61 to 0.72. x-distance correlations are highest in all three games, whereas radial distance correlation coefficients are lowest. Exemplar centroid data is depicted in the panels on the left of figure 3.

For the surface area measures, correlation coefficients are lower compared to the correlations for the centroid time series (table 1). Values for length are between 0.30 and 0.36, whereas values for width and surface area are close to zero. Exemplar data for length, width and surface area are presented in panels on the right of figure 3.

*Table 1. Pearson correlation coefficients (r) for centroid positions and surface areas of two teams during three small-sided games.*

Game	Centroid			Surface area		
	<i>r</i> x-distance	<i>r</i> y-distance	<i>r</i> radial	<i>r</i> Length	<i>r</i> Width	<i>r</i> Surface area
Game 1	0.95*	0.82*	0.61*	0.30*	-0.01	0.03
Game 2	0.94*	0.80*	0.72*	0.36*	-0.03*	0.07*
Game 3	0.94*	0.80*	0.70*	0.35*	-0.01	-0.01

\* = significant at 0.01 level (2-tailed)

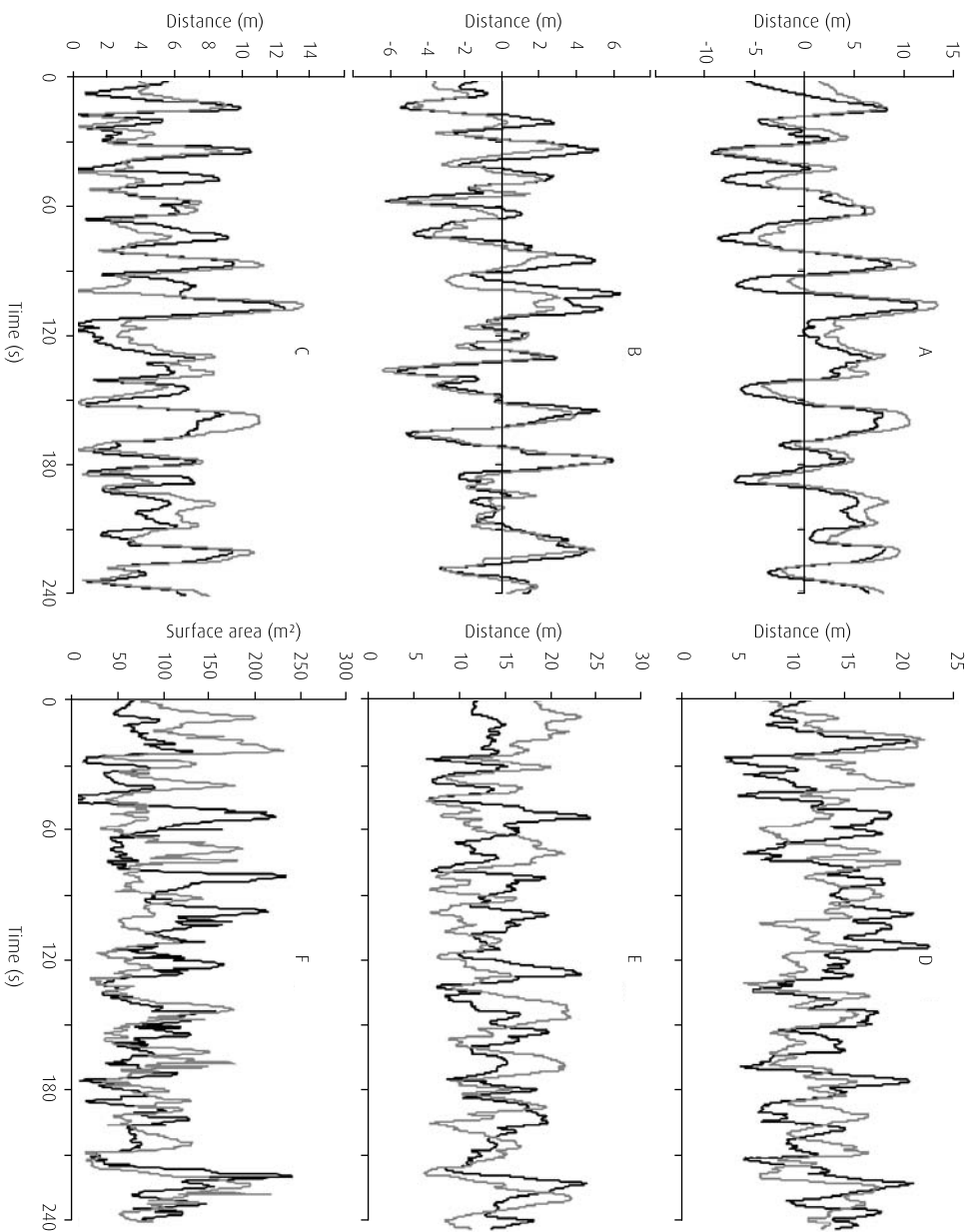

Figure 3. Exemplar time series data of 4 minutes of a small-sided soccer game for centroid (with a) x- distance, b) y- distance, c) radial distance) and surface area (with d) length, e) width, f) surface area). Black and grey lines are consistently used for the same team in all panels.

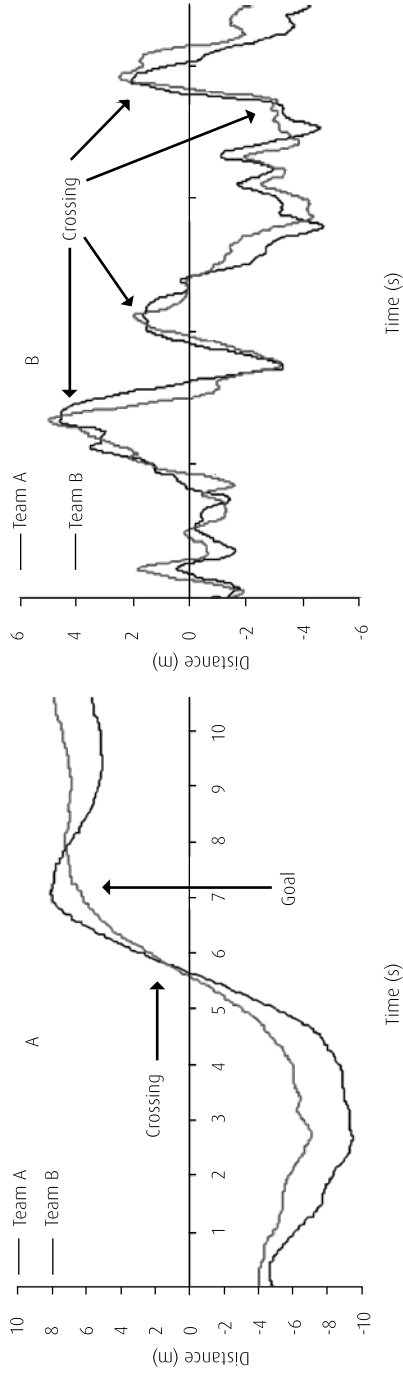

Figure 4. Exemplar crossing of centroids for  
a) x-distance when a goal is scored and b) y-distance. Time scales differ between panels.

### Goals

In total, 19 goals were scored, of which 6 originated from individual play (32 %), 5 from deep passes (26 %), 3 from crosses (16 %), 3 from team play (16 %) and 2 from long range shots (11 %). As can be seen in figure 3, during the course of the game the centroids of both teams closely follow each other in forward-backward direction (x-distance). For 10 out of 19 goals (53 %), a crossing of the centroid positions in forward-backward direction can be seen prior to a goal is scored. They occur for all types of attack. On these ten occasions, the centroid of the attacking team overtakes the centroid of the defending team. So, crossings only occur prior a goal; they are absent for the remainder of the game. This phenomenon is depicted in figure 4a; in which seconds prior to the goal a crossing can be seen. Crossings in lateral direction (y-distance) occur frequently as the games evolve. In figure 4b, exemplar data is depicted in which several lateral crossings are marked. However, lateral crossings are absent prior to a goal. Contrary to centroid data, no specific patterns were detected for all surface area measures prior to goals.

### Discussion

This study is the first step in the development of a model that may capture the rhythmic flow of attacking and defending in soccer

at team level. The primary aim was to establish an overall linear association per game for centroid positions of two teams and surface areas of two teams in three small-sided soccer games. In addition, the aim was to identify patterns in the build-up of goals for these variables. Along with the innovative tracking technology, these analyses improve our understanding of complex team sports like soccer and give rise to new directions of scientific research and new practical tools for coaches.

Our first hypothesis was the presence of an overall positive linear relation for the position of the centroids for each small-sided game. Correlations are near perfect for the forward-backward oscillations for all three small-sided games, 0.95, 0.94 and 0.94 respectively. Although slightly lower, correlation coefficients for the lateral oscillations of the centroids are high for the three respective games (0.82, 0.80 and 0.80). These results confirm that the centroids tend to move in the same direction over the course of a game. This is in line with previous research (Lames *et al.*, 2008), although this was found in an 11-a-side match. Furthermore, our results indicate that the association is stronger for forward-backward oscillations in comparison with the lateral oscillations of the centroid. Therefore, this can be considered the most dominant direction of play. This is in accordance with the general rules of



the game, in which the aim is to score a goal at the opposite side of the pitch. In other words, players must go forward to score a goal. However, passing the ball from left to right might only be the way to achieve this, which results in a less strong relation. So, in each game, association in forward-backward direction is stronger compared to lateral direction. Whether forward-backward and lateral motions of the centroids are coordinated differently throughout the game remains unknown and future studies should address this. As a result of the less strong lateral relation between teams, radial distance of the centroids is moderately correlated in all three games; 0.61, 0.72 and 0.70 respectively.

Secondly, we hypothesized a negative linear relation for surface area oscillations of the teams. Our results did not confirm this, because correlations are near zero for the three games (0.03, 0.07 and -0.01). This implies no linear association for the surface areas of the teams. It can be argued that this is due to the type of small-sided games used in this study. Although these games were organized to be maximally representative of full-sized matches, this type of game invites players to change positions constantly and to make runs without the ball to free up space for teammates. So, although these games can be considered a sub-phase of an 11-a-side match, it can be assumed that players act within

a different set of constraints compared to full-sized matches. This also holds for the centroid data. However, in the current study, we did not examine the extent of the effect of the constraints on the key variables. Furthermore, the relative contribution of an individual player to the surface area of that particular team is large, since the teams consist of four outfield players. Therefore, if one player makes a run in a random direction, it immediately affects the surface area. Therefore, play is less structured which results in the absence of the hypothesized surface area pattern, i.e. simultaneous freeing up space of one team and tying up space of the other team.

Likewise surface area, length and width do not reveal any linearity. This is supported by the correlation coefficients of length (0.30, 0.36 and 0.35) and width (-0.01, -0.03 and -0.01) for the three respective games. Although correlations are low, highest correlations are found for the longitudinal direction, which again points at this direction being dominant. Our analyses of all surface area measures focused on the presence of an overall pattern over the course of a game. Although our data does not confirm the hypothesized pattern, this does not necessarily mean that it is not present during the game. The present statistical method neglects changes over time as the game evolves. In order to incorporate the changes over time and to de

termine the coordination patterns more specifically, more advanced statistical tools are required, as discussed later. This reasoning also applies to our centroid data and future studies should address this.

Our final hypothesis was that deviations in patterns of centroid and surface area measures would indicate goal-scoring opportunities. In net games like tennis and squash, deviations from primarily stable antiphase patterns precede the end of a rally (McGarry *et al.*, 1999; Palut & Zanone, 2005). In the current study, we tried to identify these deviations by means of backtracking from the goals. We found a distinct pattern for the forward-backward displacement of the centroid ( $x$ -distance). For 10 out of 19 goals, the centroid of the attacking team crosses the centroid of the defending team (figure 4a). Although less prominent as reported previously (Frencken & Lemmink, 2008), this phenomenon is clearly present nonetheless. Furthermore, the crossing of the centroids occurs for all types of attack, which indicates that this might be a prerequisite for at least increasing the odds to score a goal. On the other hand, this phenomenon was absent for 9 out of 19 goals. In those cases, we were unable to identify clear deviations. Possible explanations are of conceptual nature. If the attack is not executed by all members of the attacking team and one player decides to stay back during the attack, the centroid does not move

forward and does not overlap. Also, if players of a team diverge or converge to the same extent relative to the ball position, the position of the centroid does not change. Although these are conceptually true, they can be considered hypothetical conditions that are unlikely to occur in a continuously changing environment with many degrees of freedom, like small-sided games. This is also supported by our data. Video analysis of player runs and examination of positional data show that the centroids of both teams are not stationary in subsequent samples and therefore change positions continuously during all three games. This is also demonstrated in figure 3. A more practical argument that explains the absence of crossing centroids is that whether a goal is scored or not depends on technical skills of the players, i.e. the ability to convert an opportunity into a goal. Taking this together, it remains unclear if there are genuine conceptual limitations to the centroid variable. Our data indicate that this is not the case, however future studies should also address this. Nevertheless, the fact that the centroids do not cross prior all goals, but seem to cross only during goals in contrast to general game play, suggests that this is a specific characteristic of a goal. In contrast with these findings, we were unable to find recurrent or systematic deviations in the patterns preceding goals for lateral (figure 4b) and radial oscillations of the centroid and for all surface area

related measures. As previously mentioned, the use of small-sided games does not facilitate pattern development for these measures in small-sided games. Therefore, it would be important to examine the patterns of these variables in full-sized matches.

In order to go beyond the current study, cross-correlation functions (CCF) could be calculated. In the present study, we calculated total correlation coefficients to investigate if a linear relationship for centroid position and surface area could be established that describes the flow of attacking and defending in over the course of a whole game. This analysis does not specifically take into account temporal changes. CCF calculations cover for this. Therefore, that approach allows for a more detailed analysis of the game dynamics over time and will provide further insight to stable and instable phases during a game. This will give a more quantitative evaluation of this type of data and we move a step closer towards a formal system description. This not only holds for centroid data, but also for surface area data. Alternatively, calculations of relative phase may yield valuable information. Theoretically, this is the most powerful variable and has shown to be useful in tennis (Lames, 2006; Palut & Zanone, 2005) and basketball (Bourbousson *et al.*, 2010a; Bourbousson *et al.*, 2010b). However, it remains to be seen, whether the type of oscillations as shown in this

study are suited for such analyses. To conclude, in this study we conceptualized a team sport, soccer, as a dynamical system with many individual players giving rise to general team behaviour. Our aim was to establish positive and negative linear relations per game for the centroid positions and surface areas respectively as a first step towards a model that captures the dynamics of a soccer match at team level. Hereto, we calculated correlation coefficients for all measures for three small-sided soccer games. Our results mainly indicate a strong positive linear relation for the centroid positions of both teams over the course of a whole game. The forward-backward motion of the centroid seems to be dominant and most related to goals in small-sided soccer games. Surface area related measures were less correlated for various reasons. The next step is to use these variables in future studies in which time evolution is incorporated. Furthermore, specific properties of a dynamical system should be established to further improve our understanding of game dynamics at team level. Match data of different type and playing levels would be extremely useful in this respect. This approach provides valuable information to sports scientists to increase the understanding about the game and provide coaches with practical tools to better guide the daily training process.

## REFERENCES

1. > Araújo, D., Davids, K., Bennett, S.J., Button, C., & Chapman, G. (2004). Emergence of sport skills under constraints. In A.M. Williams & N. J. Hodges (Eds.), *Skill Acquisition in Sport: Research, Theory and Practice* (pp. 409-433). London: Routledge, Taylor & Francis.
2. > Bourbousson, J., Sève, C., & McGarry, T. (2010a). Space-time coordination dynamics in basketball: Part 1. Intra- and inter-couplings among player dyads. *Journal of Sports Sciences*, 28, 339-347.
3. > Bourbousson, J., Sève, C., & McGarry, T. (2010b). Space-time coordination dynamics in basketball: Part 2. The interaction between the two teams. *Journal of Sports Sciences*, 28, 349-358.
4. > Carling, C., Bloomfield, J., Nelsen, L., & Reilly, T. (2008). The role of motion analysis in elite soccer: Contemporary performance measurement techniques and work rate data. *Sports Medicine*, 38, 839-862.
5. > Carling, C., Williams, A.M., & Reilly, T. (2005). *Handbook of soccer match analysis: A systematic approach to improving performance*. London: Routledge.
6. > Davids, K., Araújo, D., Button, C., & Renshaw, I. (2007). Degenerate brains, indeterminate behavior and representative tasks: Implications for experimental design in sport psychology research. In G. Tenenbaum & B. Eklund (Eds.), *Handbook of Sport Psychology* (pp. 224-244). Hoboken, NJ: John Wiley.
7. > Drust, B., Atkinson, G., & Reilly, T. (2007). Future perspectives in the evaluation of the physiological demands of soccer. *Sports Medicine*, 37, 783-805.
8. > Frencken, W.G.P. & Lemmink, K.A.P.M. (2008). Team kinematics of small-sided soccer games: A systematic approach. In T. Reilly & F. Korkusuz (Eds.), *Science and Football VI* (pp. 161-166). London and New York: Routledge.
9. > Graham, R.L. (1972). An efficient algorithm for determining the convex hull of a finite planar set. *Information Processing Letters*, 1, 132-133.
10. > Gréhaigne, J.F., Bouthier, D., & David, B. (1997). Dynamic-system analysis of opponent relationships in collective actions in soccer. *Journal of Sports Sciences*, 15, 137-149.
11. > Haken, H., Kelso, J.A.S., & Bunz, H. (1985). A theoretical model of phase-transitions in human hand movements. *Biological Cybernetics*, 51, 347-356.
12. > Hill-Haas, S., Coutts, A., Rowsell, G., & Dawson, B. (2008). Variability of acute physiological responses and performance profiles of youth soccer players in small-sided games. *Journal of Science and Medicine in Sport*, 11, 487-490.
13. > Hughes, M.D. & Bartlett, R.M. (2002). The use of performance indicators in performance analysis. *Journal of Sports Sciences*, 20, 739-754.
14. > Jones, S. & Drust, B. (2007). Physiological and technical demands of 4 v 4 and 8 v 8 games in elite youth soccer players. *Kinesiology*, 39, 150-156.
15. > Kelso, J.A.S. (1984). Phase-transitions and critical behavior in human bimanual coordination. *American Journal of Physiology*, 246, 1000-1004.
16. > Kugler, P.N., Kelso, J.A.S., & Turvey, M.T. (1980). On the concept of coordinated structures as dissipative structures. I: Theoretical lines of convergence. In G. Stelmach & J. Requin (Eds.), *Tutorials in motor behavior* (pp. 3-45). Amsterdam: North Holland.
17. > Lames, M. (2006). Modelling the interaction in game sports - Relative phase and moving correlations. *Journal of Sports Science and Medicine*, 5, 556-560.
18. > Lames, M., Erdmann, J., & Walter, F. (2008). Oscillations in football - order and disorder in spatial interactions between the two teams. *Book of abstracts of the 2nd ICCSS*, 114-115.
19. > Little, T. & Williams, A.G. (2006). Suitability of soccer training drills for endurance training. *Journal of Strength and Conditioning Research*, 20, 316-319.
20. > McGarry, T. (2005). Soccer as a dynamical system: Some theoretical considerations. In T. Reilly & D. Araújo (Eds.), *Science and Football V* (pp. 561-570). London: Routledge.
21. > McGarry, T., Anderson, D.I., Wallace, S.A., Hughes, M.D., & Franks, I.M. (2002). Sport competition as a dynamical self-organizing system. *Journal of Sports Sciences*, 20, 771-781.
22. > McGarry, T. & Franks, I.M. (1996). Development, application, and limitation of a stochastic Markov model in explaining championship squash performance. *Research Quarterly for Exercise and Sport*, 67, 406-415.
23. > McGarry, T., Khan, M.A., & Franks, I.M. (1999). On the presence and absence of behavioural traits in sport: An example from championship squash match-play. *Journal of Sports Sciences*, 17, 297-311.



- Palut, Y. & Zanone, P.G. (2005). A dynamical analysis of tennis: Concepts and data. *Journal of Sports Sciences*, 23, 1021-1032. < 24.
- Passos, P., Araujo, D., Davids, K., Gouveia, L., Milho, J., & Serpa, S. (2008). Information-governing dynamics of attacker-defender interactions in youth rugby union. *Journal of Sports Sciences*, 26, 1421-1429. < 25.
- Passos, P., Araujo, D., Davids, K., Gouveia, L., & Serpa, S. (2006). Interpersonal dynamics in sport: The role of artificial neural networks and 3-D analysis. *Behavior Research Methods*, 38, 683-691. < 26.
- Reed, D. & Hughes, M. (2006). An exploration of team sport as a dynamical system. *International Journal of Performance Analysis in Sport*, 6, 114-125. < 27.
- Richardson, M.J., Marsh, K.L., Isenhowe, R.W., Goodman, J.R.L., & Schmidt, R.C. (2007). Rocking together: Dynamics of intentional and unintentional interpersonal coordination. *Human Movement Science*, 26, 867-891. < 28.
- Schmidt, R.C., Carello, C., & Turvey, M.T. (1990). Phase-transitions and critical fluctuations in the visual coordination of rhythmic movements between people. *Journal of Experimental Psychology-Human Perception and Performance*, 16, 227-247. < 29.
- Schmidt, R.C., O'Brien, B., & Sysko, R. (1999). Self-organization of between-persons cooperative tasks and possible applications to sport. *International Journal of Sport Psychology*, 30, 558-579. < 30.
- Schmidt, R.C., Shaw, B.K., & Turvey, M.T. (1993). Coupling dynamics in interlimb coordination. *Journal of Experimental Psychology-Human Perception and Performance*, 19, 397-415. < 31.
- Schmidt, R.C. & Turvey, M.T. (1994). Phase-entrainment dynamics of visually coupled rhythmic movements. *Biological Cybernetics*, 70, 369-376. < 32.
- Stelzer, A., Pourvoyeur, K., & Fischer, A. (2004). Concept and application of LPM-A novel 3-D local position measurement system. *IEEE Transactions on Microwave Theory and Techniques*, 52, 2664-2669. < 33.
- Stolen, T., Chamari, K., Castagna, C., & Wisloff, U. (2005). Physiology of soccer - An update. *Sports Medicine*, 35, 501-536. < 34.
- Tessitore, A., Meeusen, R., Piacentini, M.F., Demarie, S., & Capranica, L. (2006). Physiological and technical aspects of "6-a-side" soccer drills. *Journal of Sports Medicine and Physical Fitness*, 46, 36-43. < 35.





# VARIABILITY OF INTER-TEAM DISTANCES ASSOCIATED WITH MATCH EVENTS IN ELITE-STANDARD SOCCER

Wouter G.P. Frencken <sup>1</sup>  
Harjo J. de Poel <sup>1</sup>  
Chris Visscher <sup>1</sup>  
Koen A.P.M. Lemmink <sup>1,2</sup>

*1 University Medical Center Groningen,  
University of Groningen  
Center for Human Movement Sciences  
Groningen  
The Netherlands*

*2 Hanze University of Applied Sciences  
School of Sports Studies  
Groningen  
The Netherlands*

## *Abstract*

In soccer, critical match events like goal attempts can be preceded by periods of instability in the balance between the two teams' behaviours. Therefore, we determined periods of high variability in the distance between the teams' centroid positions longitudinally and laterally in an international-standard soccer match and evaluated corresponding match events. Position data were collected with AMISCO Pro®. Inter-team distance variability was calculated over a 3-s moving window. Out of the 242 match periods that exceeded the variability criterion, 51 were dead-ball situations. Match events identified through longitudinal inter-team distance primarily related to defending players moving forward-backward after a longitudinal pass. Match events identified through lateral inter-team distance mainly corresponded with defending players moving laterally following sideways passing. One of two goals and two of fourteen goal-attempts were preceded by a period of high variability. Together, periods of highly variable inter-team distance were associated with collective defensive actions and team reorganization in dead-ball moments rather than goals or goal attempts. Inter-team dynamics quantified (mutual) reorganization of the teams and marked teams' collective defensive ability to respond to attacking explorations.

*In: Journal of Sports Sciences. (2012).  
30(12), 1207-1213.*

**Dynamical systems,  
Perturbations,  
Tactics,  
Performance,  
Team sports**

# INTRODUCTION

Sports scientists investigate a wide range of topics on match performance in team sports. Although match performance is subject to interactions of all players involved, these interactions have been understudied even though they influence performance (Bourbousson, Sève & McGarry, 2010b; Palut & Zanone, 2005). Incorporating these interactions in scientific studies has been recognized a challenge in sport science (McGarry, 2009). Such an approach reflects the complexity of team sports, facilitates tactical analyses and thus enhances our understanding of sports performance in general. Both for individual players and teams in interactive sports, information from such analyses could improve preparations for competition.

McGarry, Anderson, Wallace, Hughes & Franks (2002) proposed the notion of time-space dependent cooperative intra-couplings between players in a team and competitive inter-couplings between players of different teams. Continuously changing player positions that result from players' tactical decisions reflect the interactions (Passos, Milho, Fonseca, Borges, Araújo *et al.*, 2011) and give rise to dynamic patterns of play and typical team sports behaviours. This also implies that complex patterns can be derived from spatial-temporal match dynamics that result from players' movements. Two major challenges arise from this (Walter, Lames & McGarry, 2007). First, identification of variables that describe the patterns and second, quantification of interaction processes. The first challenge has been addressed in individual sports like tennis and squash, by describing patterns as oscillations around a specific point on the playing surface, e.g. the "T" in squash. The second challenge has been addressed predominantly by calculating phase relations between either position or speed data of two players. This provided insights in stable and preferred coordination patterns, critical periods of play and dynamic processes through which match behaviour was established (e.g. McGarry, Khan & Franks, 1999; McGarry & Walter, 2007; Palut & Zanone, 2005; Walter *et al.*, 2007).

Similar research has been conducted at individual and team level in team sports like soccer, basketball and rugby (e.g. Araújo, Davids, Bennett, Button & Chapman, 2004; Bourbousson Sève & McGarry, 2010a; 2010b; Frencken & Lemmink, 2008; Frencken, Lemmink, Delleman & Visscher, 2011; Lames, 2006; Lames, Erdmann & Walter, 2008; Passos *et al.*, 2008). Compared with racket sports, team sport athletes in invasion games tend not to move in a fixed field position, although they are generally confined to a specific area dependent on their role. This complicates quantification of interaction processes between players or teams grounded in coupled oscillator dynamics (McGarry *et al.*, 2002). Although not overly present, evidence for oscillatory behaviour at team level in team sports has been provided from small-sided soccer games (Frencken & Lemmink, 2008; Frencken *et al.*, 2011), full-sized

soccer matches (Lames *et al.*, (2008) and specific match situations in basketball (Bourbousson *et al.*, 2010b). In these studies, the centroid positions (i.e. geometrical centres) of both teams were monitored over time in longitudinal and lateral directions, as the interaction reflects the continuous flow of attacking and defending of two teams (Frencken *et al.*, 2011). Indeed, the centroid positions are entrained longitudinally to a high degree as indicated by correlations greater than 0.94 between time series data of teams' centroids over the duration of small-sided soccer games (Frencken *et al.*, 2011). Analogously, basketball data revealed relative phase distributions around 0 in many match situations, implying in-phase relations (Bourbousson *et al.*, 2010b). Similar results appeared for the centroid positions laterally, although correlations and relative phase distributions were less prominent (Frencken *et al.*, 2011; Bourbousson *et al.*, 2010b). As such, patterns reflect the two teams moving up and down the field to arrive in scoring positions or prevent that from happening (Gréhaigne *et al.*, 1997).

Despite this evidence for such patterns, it remains unclear how they evolve in a match and if, for instance, sudden pattern changes relate to specific match events. This has been denoted as an hiatus (Bourbousson *et al.*, 2010b). With little evidence, visual assessment of small-sided soccer games data has shown that specific patterns occurred prior to goal-scoring opportunities and goals (Frencken & Lemmink, 2008; Frencken *et al.*, 2011). On these occasions, the distance between centroid positions was small, sometimes even reversed, or there was a discrepancy in the rate of change of the teams' centroid positions displacements. Bourbousson and colleagues (2010b) reported similar qualitative findings, stating that relative phase was disrupted on some occasions around the incidence of important match events, mainly changes in ball possession of the teams. Together, this suggests that inter-team distance (i.e. distance between teams' centroid positions) is a variable that captures the match's dynamics. Moreover, given that periods of instability of the interaction patterns reflect perturbations of the system (McGarry *et al.*, 2002), increased variability of inter-team distances reflects perturbations that precede critical match events and disrupt the balance between two teams. In addition, if pattern changes of such a variable are beneficial to a team's match performance, the inter-team distance could be an underlying mechanism for new tactical key performance indicators in match analysis.

Given that principles of dynamical systems apply to various levels of analysis and the representative nature of small-sided soccer games for full-sized soccer matches (Davids, Araújo, Button & Renshaw, 2007), along with evidence from full-sized matches (Lames *et al.* 2008), we anticipate that the typical oscillations occur in full-sized soccer matches when evaluating the dynamics

of the teams' centroid positions. Therefore we investigate and evaluate an elite-standard soccer match by analyzing match dynamics through continuous calculations of instantaneous variability of inter-team distance. This advances previous studies in which either specific match situations were isolated prior to analysis of position data (Bourbousson *et al.*, 2010b) or qualitative analysis of the total match was performed (Frencken *et al.*, 2011). So, the aim of this study was to see if inter-team distance dynamics correspond to match events through continuous analysis of variability. We hypothesized that periods of high variability in inter-team distance would indicate critical match periods like goal-scoring opportunities or goals.

## Methods

### Design and participants

Twenty-five elite-standard soccer players (aged  $27 \pm 3$  years) competed in a UEFA Champions League quarterfinal match in the 2008-2009 season, in which one goal was scored by each team in the second half. The match was played on a  $105 \times 68$  m pitch. Player positions were recorded with the AMISCO Pro® video-tracking system at 10 Hz. Details of the tracking system (Carling, Williams & Reilly, 2005; Carling, 2008) and its reliability and validity are described elsewhere (Zubillaga, 2006). All procedures in this study were in accordance with the guidelines of the Medical Ethical Committee of the University Medical Center Groningen, University of Groningen, Groningen, the Netherlands.

### Data analysis

Position data were used to calculate two variables: longitudinal and lateral inter-team distances. These distances were defined as the difference, longitudinally and laterally, between centroid positions of both teams. A team's centroid is a geometrical configuration that represents the mean position of a group of points, here the 10 outfield players of a team, as the goalkeeper is excluded from centroid calculations because of the particular field position (Frencken *et al.*, 2011).

First, means and standard deviations were calculated for longitudinal and lateral inter-team distances, for first and second half. Second, Pearson correlation coefficients were calculated for the centroid positions of both teams longitudinally and laterally for both halves. Subsequently,  $R^2$ -values were calculated per half, per measure, to indicate coupling strength between the teams (Passos *et al.*, 2011) and as a measure of effect size. Third, we calculated the standard deviation over a moving 3-s window to identify variability of longitudinal and lateral inter-team distances. In addition, rate of change of both inter-team distances was calculated. This is the first derivative of the inter-team distance and represents the speed at which it changes. The 3-s window was established after consulting a panel of five licensed professional coaches on the maximum time allowed by these coaches for a team to anticipate critical match events during a match.

Critical match periods (i.e. periods with the highest variability values) were selected using a sample-based criterion value since absolute or relative threshold values are not available. The criterion was defined as three standard deviations of the longitudinal and lateral inter-team distance variability signals, because this well-known statistical measure of three standard deviations refers to

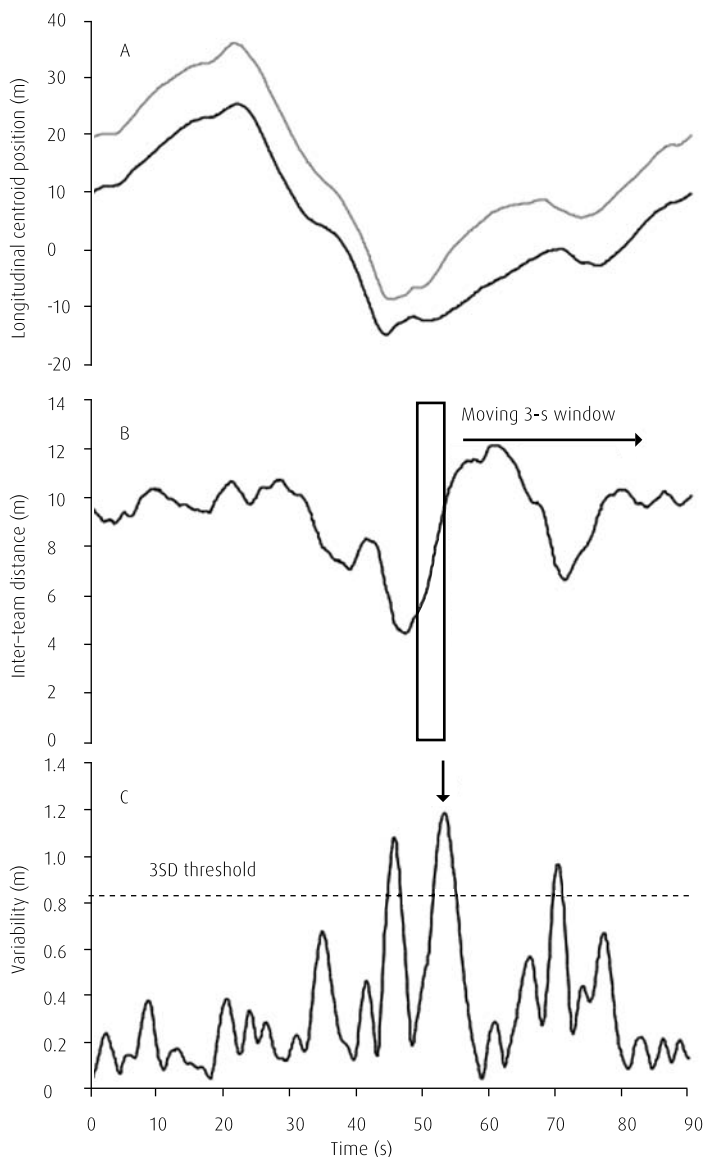

Figure 1. Exemplar data with A: Two teams' longitudinal centroid positions. Different lines represent different teams; B: Inter-team distance (difference between centroid positions as depicted in panel A). Box represents moving 3-s window for variability calculations. C: Variability signal of the inter-team distance measure. Dashed horizontal line represents the sample based criterion value of three standard deviations. Periods exceeding the criterion value are selected for closer evaluation, 3 in this example.

the proportion of data points ( $\sim 0.3\%$ ) exceeding this threshold. To exclude data artefacts, the signal had to exceed the threshold for at least two subsequent samples (0.2 s). For all critical match periods that were selected using this procedure, it was determined if the signal also exceeded the threshold for 3 s, because prolonged high variability means that the interaction between the two teams is unstable throughout that period. Given such persistent instability, these periods could be associated with the most important match events. The same threshold of three standard deviations was applied to the rate of change of longitudinal and lateral inter-team distance to select critical game periods. These periods were qualitatively video-analyzed. The subsequent steps undertaken for data-analysis are depicted in figure 1. Note that we also performed this analysis with windows of 2 and 2.5 s for variability calculations, which led to a limited number of additional critical match events next to the ones established using the 3-s window.

## Results

Mean longitudinal inter-team distance was greatest in the first half, whereas a greater variability occurred in the second half (table 1). For the lateral motion of the centroids, both mean lateral inter-team distance and its variability

Table 1. Correlation coefficients ( $r$ ), coupling values ( $R^2$ ) and longitudinal and lateral inter-team distance (m). Inter-team distances are presented as mean  $\pm$  sd.

	First Half			Second Half		
	Inter-team distance (m)	$r$ team1-team2	$R^2$ team1-team2	Inter-team distance (m)	$r$ team1-team2	$R^2$ team1-team2
Longitudinal	7.10 $\pm$ 2.29	0.99*	0.98	6.54 <sup>#</sup> $\pm$ 4.45	0.96*	0.92
Lateral	0.58 $\pm$ 2.67	0.95*	0.90	1.18 <sup>#</sup> $\pm$ 4.07	0.86*	0.73

\*significant correlations ( $p < 0.001$ )

<sup>#</sup>significantly different from first half ( $p < 0.001$ )

were greatest in the second half (table 1). Pearson correlation coefficients for both the X and Y components of the centroids of both teams were high in the first and second half, emphasized by the  $R^2$ -values (table 1). This indicates that the variance of centroid position of one team is explained by variance of centroid position of the other team and vice versa for 73 to 98 %, depending on the exact variable and matches half. Furthermore, correlations and  $R^2$ -values were greater for longitudinal inter-team distance and lower in the second half.

Threshold values for the selection of critical game periods were established at 0.83 m (variability of longitudinal inter-team distance), 0.84 m (variability of lateral inter-team distance), 1.62 m/s

(longitudinal rate of change) and 1.66 m/s (lateral rate of change). In total, 242 critical match periods were selected using these thresholds, of which 56 occurred in the first half and 52 in the second half based on the variability of longitudinal inter-team distance. More moments were included for variability of lateral inter-team distance, 67 in both the first and second half. Fifty-two match periods (21 %) were variable for at least 3 s, 14 longitudinal and 38 lateral respectively.

Thirty-eight critical match periods were selected through longitudinal and lateral rate of change and overlapped for 84 % with the moments selected on basis of variability of longitudinal and lateral inter-team distance. The other six match periods (16 %) were associ-



Figure 2: Exemplar position data of game situations identified through periods of high variability in longitudinal (A and B) and lateral (C and D) inter-team distance. Dots are outfield player positions and triangles are goalkeeper positions; fill or no fill marks different teams. Tails indicate post-3-s-postions. Ball position is represented by small, non-filled dots.

ated with moments directly after kick-offs and celebratory events after goals were scored. Thus, apart from these six events, rate of change yielded no additional match events.

Across all 242 critical match periods, 51 were associated with dead-ball situations, predominantly throw-ins (24), goal kicks (10), corner kicks (8) and free kicks (8). Next, 93 % of critical match periods selected through longitudinal inter-team distance and longitudinal rate of change were related to match events in which the ball was passed longitudinally and all players were moving forward or backwards respectively. Exemplar data are depicted in the upper panels of figure 2. Similarly, critical match events selected from lateral inter-team distance and lateral rate of change were associated with sideways passing of the team holding the ball, with primarily (87 %) the defending team collectively changing position laterally (exemplar data are depicted in lower panels of figure 2). To illustrate, in figure 2D the defending team (filled dots) moved sideways more than the attacking team (non-filled dots), demonstrated by the length of the tails. Finally, one of two goals and two out of fourteen goal attempts were preceded by a period of high variability in the 3-s window. The critical match period prior to the goal can be seen in figure 2b.

## Discussion

Monitoring teams' centroid positions during a soccer match provides insight into the rhythmic flow of attack and defence (Frencken *et al.*, 2011; McGarry *et al.*, 2002). It highlights the teams' mutual positioning over time. High variability of a relative measure based on centroid positions – here inter-team distance – indicates critical match events like goals. Therefore, the aim of this paper was to identify critical match periods by a dynamical analysis of longitudinal and lateral inter-team distances. This approach stands out from earlier studies, as critical match periods are quantitatively identified based on position data, as opposed to subjective selection of match events before evaluation of position data around these selected events. Based on qualitative data from small-sided soccer games, we predicted that these critical match periods would be associated with critical match events, e.g. goals and goal-scoring opportunities. Although we identified three such events, the main findings of this paper suggest that the inter-team distances both longitudinally and laterally are minimally related to such events in this specific match. However, critical match periods coming from changes in longitudinal direction were predominantly related to spatio-temporal movement patterns of players after longitudinal passing. Similarly, critical match

periods that were identified from changes in lateral inter-team distance were related to players' movements after sideways passing. So, all identified match periods were strongly direction-dependent and associated with changes in ball position.

The mean longitudinal inter-team distance was slightly lower in the second half. Moreover, variability doubled in the second half from 2.29 m to 4.45 m (table 1). Passos *et al.* (2011) reported similar results for interpersonal distance in an attacking subunit in rugby union. Depending on task constraints acting upon the players, functional interpersonal distances changed in attacking subunits. Although more data are needed for compelling evidence, it was argued that the stability of the interpersonal distance was constrained by the task at hand for the attackers. One implication of such task dependency is that this also holds for stability of interpersonal distances in attacker-defender player dyads and thus for interacting teams, given the universality of dynamical systems principles (Davids *et al.*, 2007). Therefore, our findings indicate an altered style of play in the second half of this match, perhaps because of altered match strategy or accumulated player fatigue. Despite the higher second half variability, the analysis did not reveal more critical match periods. This can indicate that periods of high variability on shorter

timescales, like the 3-s window adopted in this study, are more meaningful for performance than increased variability on longer timescales (e.g. 10 s or 30 s). Alternatively, different functional inter-team distances could exist and teams switch between these functional states depending on situational context to preserve balance between them. The same might apply to lateral inter-team distances, where in this match mean lateral inter-team distance and its variability were greater in the second half, possibly because of a combination of various constraints acting on the system.

The strength of the interactions between the two teams for both halves was high (table 1). The  $R^2$ -values ranged between 0.98 and 0.73, and suggest that coupling between the centroid positions was strong. Coupling was strongest longitudinally in both halves. This corresponds with a primary aim of soccer, i.e. to advance up the field to create goal-scoring opportunities (Gréhaigne *et al.*, 1997). This is supported by recent findings on individual and team level (e.g. Bourbousson *et al.*, 2010b; Frencken *et al.*, 2011; Lames *et al.*, 2008). Furthermore, coupling values in this study were higher than previous findings (Frencken *et al.*, 2008; Frencken *et al.*, 2011). This probably reflects the difference in skill between players. Here, we evaluated a senior elite-standard

match, whereas elite youth players participated in other studies. As high  $R^2$ -values indicate tight coupling, teams responded quickly to each other in this match. Possibly, lower-standard teams are more loosely coupled, meaning that they are less likely to respond adequately to each other. An underlying mechanism might be that senior elite-standard players have greater skill that allows them improved anticipation of match situations (Eccles & Tenenbaum, 2004). Such anticipation would result in increased stability in matches and a closer coupling among team measures. However, this is speculative, as our study of only one elite-standard match does not justify generalizations to other playing standards and additional research is required.

The dynamical analysis of the inter-team distances yielded 242 critical match periods. Because rate of change yielded no additional match events, we focussed on match events based on variability of longitudinal and lateral inter-team distances. Although variability exceeded the threshold prior to two of fourteen goal-scoring opportunities and before one of the two goals, the critical match periods were not strongly related to goal and goal-scoring opportunity events. This was contrary to our predictions. One explanation is that not all players are likely to be involved in, or contribute equally to, creating



goals and goal-scoring opportunities, particularly those that come from open play (Bourbousson *et al.*, 2010b; Frencken *et al.*, 2011; McGarry, 2009). Therefore, calculations of team measures for sub-units in teams might provide better predictions of goals and goal attempts. Probably, that corresponds better with evidence from small-sided soccer games in which over 50 % of the goals and goal-scoring opportunities have a distinct pattern (Frencken & Lemmink, 2008; Frencken *et al.*, 2011). However, the main challenge is to specify criteria that define ‘a sub-unit of players’ at each instance. Possibly, measures like distance to the ball or high running speeds could assist in the development of such criteria. Alternatively, it might be that relevant changes in inter-team distance occur on different timescales. Here, we used a 3-s window to calculate variability, after consensus was reached among a group of expert coaches. As 3 s might be short, time-space patterns prior to goals and goal-attempts could occur on longer timescales like 10 or 30 s, reflected by lower frequency oscillations. For instance, the continuous rhythm of attacking and defending, indicated by moving up and down the pitch as a team, implies slower oscillations than teams’ behaviour on shorter timescales like responding to passes. Because we were primarily interested in match events, we did not evaluate those longer time-scales.

We did analyze shorter 2 and 2.5-s windows, but this did not change the results. Thus, closer evaluation of oscillation frequencies could provide further insight in relevant timescales for goals and goal-scoring opportunities. For example, spectral analysis and cross-coherence analysis could be valuable.

Although one goal and two goal-scoring opportunities were determined after our dynamical analysis, the critical match periods selected from longitudinal variables were predominantly (93 %) associated with players of the defending team moving forward collectively to pressurise players of the attacking team, regardless of position on the field. This corresponds with the initial concept of inter-team distance (Frencken *et al.*, 2011), in which short distances between teams’ centroid positions reflect high defensive pressure of the defending team on the attacking team to perturb the build-up of an attack, or high attacking pressure of the attacking team on the defending team to create goal-scoring opportunities in attack. Thus, changes in inter-team distance might reflect changes in team pressure or switches between attacking and defensive pressure. This corresponds with our findings that many selected match events are related to the defensive team collectively pressurizing the ball and attacking team. Similarly, critical

lateral match events were predominantly (87 %) associated with players of the defending team collectively moving laterally after a sideways pass by the team in possession (see figure 2D). Again, this corresponds with the initial concepts of centroid positions and inter-team distance. Such a collective response of the defending team could well be an important tactical quality of the team. This is in agreement with Gréhaigne *et al.* (1997), who stated that it was important for players to manage disorder optimally. So, our findings indicate that inter-team distance dynamics mainly reflect collective behaviour of the defending team as a response to the behaviour displayed by the team in possession in order to recover the ball.

In addition, fifty-one critical match periods were related to dead-ball situations. In such situations like throw-ins, goal kicks and free kicks, players of both teams reorganize and choose positions optimally with reference to teammates, opponents, goal and ball, to establish a stable starting point for the resumption of play. So, after a period of high variability that represents the (mutual) reorganization of the teams, the system re-established stability. This corresponds with general traits of dynamical systems (Davids *et al.*, 2007; McGarry *et al.*, 2002; McGarry, 2005). Note that removing such outliers (i.e. dead-ball situations with high

variability) from the time-series data did not change the extracted critical match events. Based on these findings, we contend that longitudinal and lateral inter-team distances reflect the important tactical concept of pressurizing the opposite team in either attack or defence. Monitoring these measures during matches could indicate a team's ability to respond to the attacking team that aims to perturb the defensive system, or vice versa. For example, if a team failed to respond adequately in situations described above, disorder could emerge at any time and result in transitions in configurations of play that break the balance between the teams and transform the play (Gréhaigne *et al.*, 1997). Therefore, inter-team distances underlie new key performance indicators.

Finally, our results demonstrate that periods of high variability in inter-team distance are associated with longitudinal and lateral passes, see figure 2. This probably indicates that ball position plays a crucial role in the emergence of inter-team distance dynamics. Evidence has been provided for this recently by Travassos, Araújo, Vilar & McGarry (2011). They demonstrated that ball position drives player positions, with a stronger coupling between defenders and ball than attackers and ball. So, if ball position drives player positions, it can be anticipated that team measures based on player

positions (e.g. centroid position) are also related to ball position. This stresses the need for evaluation of ball dynamics in relation to team dynamics in future studies, along with other factors (McGarry, 2009) that constrain individual player or team behaviour.

To conclude, in the current study we performed a continuous analysis of longitudinal and lateral inter-team distances by analyzing the variability of these distances over a 3-s time scale in an elite-standard soccer match. Although generalizability is limited given the sampled match, this innovative approach that uses selected critical match periods from position data-based relative team measures - as opposed to common approaches in which specific match events were chosen beforehand after which patterns in position data were derived - marks an advance. We detected three critical match periods for goal-attempts and goals. However, our results indicated that in this match, the information from a dynamical analysis of inter-team distances most strongly relates to match events associated with pressurizing the attacking team after passes and reorganizing in dead-ball moments. One implication of these findings is that this can quantify the ability of players of the defending team collectively to respond to explorations of the attacking team to create opportunities to advance up the field to

score goals, which is of high tactical relevance. Second, it implies that inter-team distances describe a specific part of a match's dynamics and present new tactical performance indicators.

## REFERENCES

1. > Araújo, D., Davids, K., Bennett, S. J., Button, C., & Chapman, G. (2004). Emergence of sport skills under constraints. In A. M. Williams & N. J. Hodges (Eds.), *Skill Acquisition in Sport: Research, Theory and Practice* (pp. 409-433). London: Routledge, Taylor & Francis.
2. > Bourbousson, J., Sève, C., & McGarry, T. (2010a). Space-time coordination dynamics in basketball: Part 1. Intra- and inter-couplings among player dyads. *Journal of Sports Sciences*, 28, 339-347.
3. > Bourbousson, J., Sève, C., & McGarry, T. (2010b). Space-time coordination dynamics in basketball: Part 2. The interaction between the two teams. *Journal of Sports Sciences*, 28, 349-358.
4. > Carling, C., Williams, A.M. & Reilly, T. (2005) *Handbook of soccer match analysis. A systematic approach to improving performance*. London, Routledge.
5. > Carling, C., Bloomfield, J., Nelsen, L., & Reilly, T. (2008). The role of motion analysis in elite soccer: Contemporary performance measurement techniques and work rate data. *Sports Medicine*, 38, 839-862.
6. > Davids, K., Araújo, D., Button, C., & Renshaw, I. (2007). Degenerate brains, indeterminate behavior and representative tasks: Implications for experimental design in sport psychology research. In G. Tenenbaum & B. Eklund (Eds.), *Handbook of Sport Psychology* (pp. 224-244). Hoboken, NJ: John Wiley.
7. > Eccles, D.W. & Tenenbaum, G. (2004). Why an expert team is more than a team of experts: A social-cognitive conceptualization of team coordination and communication in sport. *Journal of Sport & Exercise Psychology*, 26, 542-560.
8. > Frencken, W.G.P., Lemmink, K.A.P.M., Delleman, N.J. & Visscher, C. (2011). Oscillations of centroid position and surface area of soccer teams in small-sided games. *European Journal of Sport Science*, 4, 215-223.
9. > Frencken, W.G.P. & Lemmink, K.A.P.M. (2008). Team kinematics of small-sided soccer games: A systematic approach. In T. Reilly & F. Korkusuz (Eds.), *Science and Football VI* (pp. 161-166). London and New York: Routledge.
10. > Gréhaigne, J.F., Bouthier, D., & David, B. (1997). Dynamic-system analysis of opponent relationships in collective actions in soccer. *Journal of Sports Sciences*, 15, 137-149.
11. > Lames, M. (2006). Modelling the interaction in game sports - Relative phase and moving correlations. *Journal of Sports Science and Medicine*, 5, 556-560.
12. > Lames, M., Erdmann, J., & Walter, F. (2008). Oscillations in football - order and disorder in spatial interactions between the two teams. *Book of abstracts of the 2nd ICCSS*, 114-115.
13. > McGarry, T. (2005). Soccer as a dynamical system: Some theoretical considerations. In T. Reilly & D. Araújo (Eds.), *Science and Football V* (pp. 561-570). London: Routledge.
14. > McGarry, T. (2009) *Applied and theoretical perspectives of performance analysis in sport: Scientific issues and challenges*. *International Journal of Computer Science in Sport*, 9, 128-140.
15. > McGarry, T., Anderson, D.I., Wallace, S.A., Hughes, M.D., & Franks, I.M. (2002). Sport competition as a dynamical self-organizing system. *Journal of Sports Sciences*, 20, 771-781.
16. > McGarry, T., Khan, M.A., & Franks, I.M. (1999). On the presence and absence of behavioural traits in sport: An example from championship squash match-play. *Journal of Sports Sciences*, 17, 297-311.
17. > McGarry, T. & Walter, F. (2007). On the detection of space-time patterns in squash using dynamical analysis. *International Journal of Computer Science in Sport*, 6, 42-49.
18. > Palut, Y. & Zanone, P.G. (2005). A dynamical analysis of tennis: Concepts and data. *Journal of Sports Sciences*, 23, 1021-1032.
19. > Passos, P., Araújo, D., Davids, K., Gouveia, L., Milho, J., & Serpa, S. (2008). Information-governing dynamics of attacker-defender interactions in youth rugby union. *Journal of Sports Sciences*, 26, 1421-1429.
20. > Passos, P., Milho, J., Fonseca, S., Borges, J., Araújo, D. & Davids, D. (2011). Interpersonal distance regulates functional grouping tendencies of agents in team sports. *Journal of Motor Behaviour*, 43(2), 155-163.
21. > Travassos, B., Araújo, D., Vilar, L. & McGarry, T. (2011). Interpersonal coordination and ball dynamics in futsal (indoor football). *Human Movement Science*, 30(6), 1245-59.
22. > Walter, F., Lames, M. & McGarry, T. (2007). Analysis of sports performance as a dynamical system by means of the relative phase. *International Journal of Computer Science in Sport*, 6(2), 35-41.
23. > Zubillaga, A. (2006). *La actividad del jugador de fútbol en alta competición: análisis de variabilidad*. (Football player's activity in high level competition: Variability analysis) Thesis Doctoral: Universidad de Malaga.







# SIZE MATTERS: PITCH DIMENSIONS CONSTRAIN INTERACTIVE TEAM BEHAVIOUR IN SOCCER

Wouter G. P. Frencken <sup>1,2,3</sup>

Jorrit van der Plaats <sup>1</sup>

Chris Visscher <sup>1</sup>

Koen A. P. M. Lemmink <sup>1,2</sup>

*1 University Medical Center Groningen,  
University of Groningen  
Center for Human Movement Sciences  
Groningen  
The Netherlands*

*2 Hanze University of Applied Sciences  
School of Sports Studies  
Groningen  
The Netherlands*

*3 Football Club Groningen  
Groningen  
The Netherlands*

## Abstract

Pitch size varies in official soccer matches and differently sized pitches are adopted for tactical purposes in small-sided training games. Since interactive team behaviour emerges under constraints, we evaluated the effect of pitch size (task) manipulations on interactive team behaviour in small-sided soccer games. Four 4-a-side (plus goalkeepers) small-sided games were played: a reference game (30x20 m), length manipulation (24x20 m), width manipulation (30x16 m) and a combination (24x16 m). Using position data (100 Hz), three measures quantifying the teams' interaction were calculated: longitudinal inter-team distance, lateral inter-team distance and surface area difference. Means and standard deviations, correlations and coupling values were calculated. Running correlations were calculated over a 3-s window to evaluate interaction patterns. As expected, a shorter pitch results in smaller longitudinal inter-team distance, lateral inter-team distance decreased for narrow pitches and smaller total playing area resulted in decreased surface area. Unanticipated, a crossover effect was present; length and width manipulations also triggered changes in lateral and longitudinal direction respectively. Inter-team distances and surface area difference differed significantly across conditions. Interaction patterns differed across conditions for all measures. So, highly tactically relevant, soccer teams seem to adapt their interactive behaviour according to pitch size in small-sided games.

*In: Journal of Systems Science and Complexity; Complex Systems and Sports, (Accepted).*

**Dynamics,  
Tactics,  
Constraints,  
Small-sided games,  
Performance analysis**

# INTRODUCTION

In complex systems, spatial-temporal patterns arise from local interactions of components that comprise the system. Players are considered to be these interactive components in team sports like rugby, basketball and soccer. Interactions of players within a team and between players of different teams are thought to give rise to the sport specific patterns (Davids *et al.*, 2005; McGarry *et al.*, 2002). The former are considered intra couplings, whereas the latter is referred to as inter couplings. Such interactions between players are formed and broken continuously. Normally, local information governs the specific coupling between persons (Passos *et al.*, 2011). In this respect, some experimental work has been performed in player-player dyads in basketball (Araújo *et al.*, 2004). Here an attacker had to pass the defender in order to score. The aim of the defender was to prevent the goal attempt. So, where the attacker seeks to disrupt the balance in the dyad, the defender aims to maintain balance and remain in position between attacker and basket. One conclusion was that information that specifies the interaction seemed to emerge within the specific performance context.

The same line of reasoning can be applied to team sports game situations that involve more players. Here, the opposition relation between players of different teams means that at every instant, some or all players aim to achieve a specific goal. Whilst doing so, players within a team are cooperating to score a goal, or to prevent the opposition from scoring. Thus, all players cooperate and compete simultaneously. Hereto, continuous player movements are required to choose tactically relevant positions on the field, relative to opponents, teammates, ball and goals. So, information based on speed and direction of players and ball seem to govern tactical decisions by players (Gréhaigne *et al.*, 1997). This infers that changes in player positions on the field reflect coupling between players and as such changes in interpersonal distances could therefore be measures of the systems' state. (Passos *et al.*, 2011). Some evidence confirming this has been provided in basketball (Araújo *et al.*, 2004) and rugby (Passos *et al.*, 2011).

In similar fashion, a coupling between the two teams is present. Such entrainment of team parameters like the teams' centroids (geometrical centers) and surface areas, has been established in various studies (Bourbousson *et al.*, 2010; Frencken & Lemmink, 2008; Frencken *et al.*, 2011). The surface area, longitudinal and lateral movement of centroid positions of two teams during a match are thought to reflect the flow of attacking and defending (Frencken *et al.*, 2011; McGarry *et al.*, 2002). Moreover, inter-team distance also seems to be associated with critical and tactically relevant game events following a dynamical analysis of an elite soccer match (Frencken *et al.*, 2012). So, similar to player-player dyads, the distance between the teams' centroids and difference in surface area reflect the interaction process between teams.



In dynamical systems, the functional interaction patterns expressed in a specific performance context emerge under constraints. In systems like sports, tasks constrain spatial-temporal patterns, next to environment and person-associated factors (Newell, 1986). Among other tasks (Passos *et al.*, 2011; Travassos *et al.*, 2011), pitch size is considered to constrain spatial-temporal player behaviour in small-sided soccer games. Pitch size manipulations indicate that, for example, increased relative playing area per player increases exercise intensity and influences players' movement patterns (Hill-Haas *et al.*, 2011). Besides, it has been suggested that small-sided games are useful technical and tactical training tools frequently used in practice (Coutts *et al.*, 2009; Hill-Haas *et al.*, 2011; Tessitore *et al.*, 2006). Because pitch size manipulations have shown to affect players' spatial-temporal movement patterns, and players comprise the two interacting teams, we argue that team behaviour, measured by centroid position and surface area, may also be constrained by pitch size. As a consequence, also the interaction process between two teams, reflected by inter-team distances or the surface area difference, could be affected by pitch size. However, changes in teams' tactical behaviour and the effects of pitch size manipulations on it, have not been addressed in scientific studies to date.

Therefore, the aim of the current study is to evaluate the effect of three pitch size manipulations on longitudinal and lateral inter team distance and the surface area difference. We expect that a decreased pitch length results in decreased longitudinal inter-team distance, given the same pitch width. Similarly, we expect that decreased pitch width results in decreased lateral inter team distance, given the same pitch length. Finally, we hypothesize a smaller relative surface area with smaller total playing area.

## Methods

Ten amateur soccer players (age:  $22 \pm 3$  y; length:  $186 \pm 6$  cm; weight:  $78 \pm 8$  kg) participated in this study. Each player gave informed consent before data collection and all procedures were in accordance with the ethical standards of the Medical Faculty of the University Medical Center Groningen, University of Groningen, The Netherlands.

Four 4-a-side small-sided soccer games plus goalkeepers defending regular FIFA-approved goals (7,32x2,44 m) of 8 minutes were played. Eight-minute rest intervals interspersed the games and a 2-hour break separated the morning and afternoon session (2 games each). Prior to each session, a standardized warm-up of 20 minutes was conducted. Pitch dimensions in the first experimental condition (length x width) were 30x20 m. These dimensions correspond with a regular full-sized soccer pitch and are common for 4-a-side games (Frencken & Lemmink, 2008; Frencken *et al.*, 2011; Hill-Haas *et al.*, 2011). In condition 2, pitch length was reduced which resulted in a 24x20 m pitch. In condition 3, pitch dimensions were 30x16 m after width manipulation. In the fourth condition (24x16 m), both length and width were shortened, maintaining the same length to width ratio compared to condition 1. Goalkeepers were restricted to 2-touch play and outfield players

were instructed to avoid long-range shots to optimize the flow of attacking and defending. The offside rule was not applied.

The local position measurement (LPM) system (Inmotio Object Tracking BV, Amsterdam, the Netherlands) was used to collect player positions. This technology has been established as an accurate and valid tool to record player positions and speed (Frencken *et al.*, 2010). Detailed workings are described elsewhere (Frencken *et al.*, 2011; Stelzer *et al.*, 2004). Sampling frequency for an individual player was 100 Hz.

Position data was used to calculate centroid positions and surface areas of both teams (Frencken *et al.*, 2011). From the centroids of both teams, the inter-team distance in longitudinal (ITDX) and lateral (ITDY) direction were derived, i.e. the absolute distance (m) between the x and y component of the centroid positions respectively. From the surface areas of both teams, the surface area difference (SAD) was calculated, i.e. the absolute difference (m<sup>2</sup>) between the surface areas of both teams.

Means and standard deviations of ITDX, ITDY and SAD were calculated for all games. In addition, Pearson correlation coefficients (*r*) were calculated between teams' centroid positions and teams' surface areas. Subsequently, R<sup>2</sup>-values were determined as this indicates

coupling strength between the two teams (Passos *et al.*, 2011). Furthermore, running correlations were calculated for centroid and surface area time series over a moving 3-s window. This window was established after consulting a panel of 5 expert coaches on the maximal time allowed for a soccer team to respond to important game events. Evaluation of running correlations is a powerful approach to capture changes in coordination patterns between system components over time (Corbetta & Thelen, 1996), here the two teams. Correlations near 1 indicate that the direction of the change is similar for both teams and are associated with in-phase patterns, whereas correlations near -1 mean the direction of the change is opposite for both teams and point toward antiphase patterns. Correlation values of zero specify the absence of a specific pattern within the 3-s window. By rounding each correlation value, we simplified the graphical representation for qualitative evaluation of the running correlations. Values above 0,5 were rounded to 1, correlations ranging from -0,49 to 0,49 were rounded to 0 and correlations under -0,5 were rounded to -1. Finally, for the evaluation of the effect of the experimental manipulations on the ITD and SAD measures, a MANOVA was conducted. SPSS (version 18.0.3, SPSS inc., Chicago, USA) was used for the statistical procedures and statistical significance was accepted if  $p < 0.05$ .

*Table 1. Descriptives of centroid and surface area. Means  $\pm$  standard deviations of longitudinal (ITDX) and lateral (ITDY) inter-team distance and surface area difference (SAD) are presented, next to correlations (*r*) and coupling strength ( $R^2$ ).*

Game	Centroid			Surface area		
	Longitudinal		Lateral	SAD		
	ITDX (m)	<i>r</i> team 1 – team 2	ITDY (m)	<i>r</i> team 1 – team 2	$R^2$ team 1 – team 2	SAD (m <sup>2</sup> )
Condition 1 (30x20 m)	1.98 $\pm$ 1.23	0.90	1.13 $\pm$ 0.84	0.86	0.74	34 $\pm$ 29
Condition 2 (24x20 m)	1.66 $\pm$ 1.10	0.88	1.02 $\pm$ 0.77	0.82	0.67	28 $\pm$ 21
Condition 3 (30x16 m)	1.58 $\pm$ 1.10	0.91	1.96 $\pm$ 0.77	0.69	0.48	31 $\pm$ 25
Condition 4 (24x16 m)	1.48 $\pm$ 1.05	0.90	1.99 $\pm$ 0.77	0.73	0.53	38 $\pm$ 31

*Note: significant differences between all games for ITDX, ITDY and SAD. All correlations are significant at 0.001 level.*

## Results

In comparison with condition 1 (30x20 m), main observations for decreased pitch length (24x20 m) in longitudinal direction are a 15 % decrease in ITDX (1.98 m vs. 1.66 m respectively) and a reduction in coupling strength (0.81 vs 0.77 respectively). This is primarily accompanied with an increased proportion of centroids moving in the same direction simultaneously (figure 1A). Furthermore, a decrease in ITDY (1.13 m vs. 1.02 m) and a reduced coupling strength are observed in condition 2 (table 1). Running correlations indicate a decrease in the proportion of simultaneous movement of teams' centroids in the same lateral direction.

Two pairs can be compared for decreased pitch width given the same pitch length: 30x20 m vs. 30x16 m and 24x20 m vs. 24x16 m respectively. Similar trends are visible for both pairs. In both pairs, a smaller pitch width results in a decreased ITDY and reduced coupling strength between centroid positions. Proportionally, centroid positions move less in the same direction (figure 1B). An additional observation in both pairs is a decrease in ITDX for smaller pitch dimensions. In contrast to lateral displacement of the centroids, an increase in simultaneous displacement in the same direction is found.

A reduction in both pitch length and pitch width with similar length to width ratio (24x16 m) results in the largest decrease in ITDX (1.98 m vs. 1.48 m respectively) whilst coupling strength remains the same (0.81). ITDY and lateral coupling strength between centroid positions both decrease on a smaller pitch. Running correlations indicate that centroids proportionally move more in the same longitudinal direction simultaneously (figure 1A) and less in the same lateral direction (figure 1B).

Results for surface area indicate that coupling strength is near zero for all conditions (table 1). SAD decreases with decreased pitch length (30x20 m vs. 24x20 m) and with smaller width (30x20 m vs. 30x16 m). The largest SAD was observed for the smallest pitch dimension (24x16 m). Although running correlations of teams' surface areas indicate that proportionally 'no pattern' occurs most frequently (37-46 %), an attraction towards one of the other patterns is absent, as frequency distributions are similar across patterns (figure 1C).

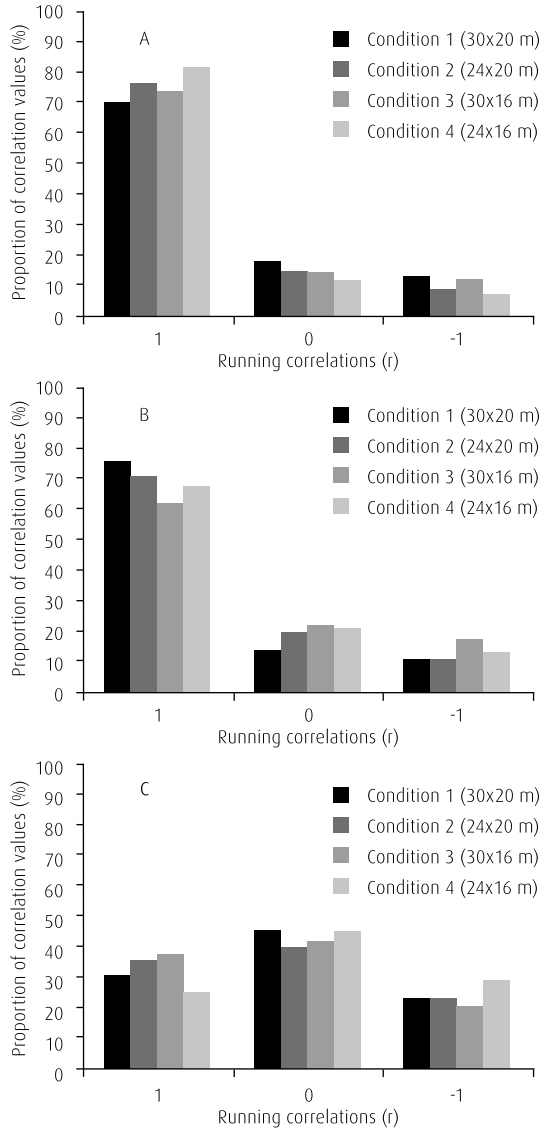

Figure 1. Histograms displaying proportion of running correlations of A) longitudinal centroid positions, B) lateral centroid positions and C) surface area's of the teams. Correlations of 1 indicate changes in the same direction, correlations of -1 indicate changes in opposite direction and correlation of 0 indicate no specific pattern.

## Discussion

Manipulations of pitch dimensions in small-sided games have shown to influence technical, running patterns and physical responses of soccer players (Hill-Haas *et al.*, 2011). Therefore, we expected that also spatial-temporal interaction patterns at team level could also be similarly constrained by pitch manipulations, since patterns emerge within a constrained performance context. Thus, the aim of the current study was to evaluate the effect of pitch size manipulations on longitudinal and lateral inter-team distance and the surface area difference.

In line with our first hypothesis, results indicate a 15 % decrease in longitudinal inter-team distance when the pitch is shortened by 20 % (30 vs. 24 m). Thus, it appears that reduced pitch length causes players to close in on each other longitudinally. One unanticipated finding is a crossover effect of pitch length reduction on lateral inter-team distance. The decrease in lateral inter-team distance is most likely a side effect of players decreasing the longitudinal distance between each other. So, we argue that as a result of the shorter pitch, players start to play closer together longitudinally. However, adapting position only in longitudinal direction, this would possibly lead to a less optimal position relative to teammates and opponents. Therefore,

players also tighten up in lateral direction. Another consequence of the shorter pitch appears to be that the teams' centroids tend to move more in the same direction longitudinally (figure 1A), whereas in the teams' centroids display a decrease of moving in the same lateral direction simultaneously. Finally, the reduced variability of inter-team distance in the shortened pitch condition (1.23 vs. 1.10 m respectively) supports the argument that teams' interactive behaviour differs across games. So, the pitch length manipulation clearly affects the inter-team dynamics measured by the distance between teams' centroids.

In similar fashion, our second hypothesis was also confirmed as smaller lateral inter-team distances were observed for conditions with reduced pitch width. Similar to the effect of pitch length manipulation, a reduced width causes players to decrease the lateral distance between each other. Despite this, coupling values are consistently lower in the reduced width conditions. It has been argued that exploiting the available space at the lateral ends by passing the ball towards these regions of the pitch is a means to advance up the field in longitudinal direction as a team (Frencken *et al.*, 2011). The availability of more lateral space at wider pitches offers players the opportunity to move in to these regions, increasing teams' lateral displacement subsequently. This

in turn facilitates entrainment of centroid positions in lateral direction, resulting in higher coupling values. Evaluation of coupling on a 3-s timescale through running correlations indicates that the type of lateral coupling shifts, judged by the decreased proportion of running correlations valued 1 (Figure 1B). So teams start to move less in the same lateral direction simultaneously.

An important additional finding is that again, a crossover effect was triggered by the pitch manipulations. Namely, results demonstrate shorter longitudinal inter-team distances for narrow pitches compared to wider pitches. Our rationale is that if players would only reduce their lateral orientation after the manipulation, their positioning in relation to teammates and opponents is disturbed. Due to this, players choose a different optimal position, hence adapting their longitudinal position also. Even more so, the teams' centroid positions tend to move more in the same direction during the game. Taking this together, interactive team behaviour, represented by teams' centroids, is altered in lateral and longitudinal direction following pitch width reductions.

In the final manipulation, length and width were reduced both to create a pitch with the same length to width ratio compared to condition 1. Main observation was

that all effects of the manipulations on inter-team distance as observed in the length only or width only conditions were present. Moreover, the decrease in longitudinal inter-team distance was proportionate to the decrease in pitch length (25 % and 20 % respectively), without a change in coupling strength. Paradoxically, the largest mean surface area difference and stronger attraction to antiphase were established in this condition. As stated before, the shorter longitudinal and lateral inter-team distances mean indicate shorter distances between players. Most likely, it becomes easier for players of the defending team to recover the ball by collectively restricting space. In its turn, the small pitch ensures that not too much space becomes available laterally for the attacking team to exploit. Consequently, if players performed a similar act of restricting space on a larger pitch, they probably give away too much space laterally. So, players seem to use the natural boundaries of the pitch differently on a smaller pitch, resulting in a stronger pattern and a larger surface area difference. Thus, a smaller field with identical length to width ratio seems to result in different interactive team behaviour compared to a larger pitch.

In regard to the other findings for teams' surface areas, we established limited differences across conditions as coupling

values are low, congruent with earlier findings (Frencken *et al.*, 2011; Frencken & Lemmink, 2008). An attraction to a specific pattern was absent (figure 1C), partially agreeing with previous findings as others found a bistable attraction for relative stretch indexes, a comparable measure of team dispersion (Bourbousson *et al.*, 2010). In our study, proportion of 'no pattern' was highest in all games. The proportions of simultaneous changes of surface are in similar direction and opposite direction were comparable but lower compared to 'no pattern'. A large reduction in pitch size results in a small decrease in relative surface area. To us, this indicated that teams' occupy similarly sized playing areas with decreased pitch size. So, although emergent patterns differ minimally across game conditions, the absolute surface area differs across conditions as expected.

Finally, our results correspond with previous research overall (Bourbousson *et al.*, 2010; Frencken *et al.*, 2011). To illustrate, we demonstrated that the strongest coupling strength between teams was found for coupling for longitudinal parameters and weaker coupling was observed for lateral parameters. Yet, correlation values in this study for specifically longitudinal and lateral centroid positions are lower than those observed in previously (Frencken *et al.*, 2011; Frencken & Lemmink,

2008). Perhaps, expertise level underlies this observation. In this study, amateur soccer players participated, whereas elite youth players participated in other studies. It has been shown that expert soccer players can extract more pertinent information related to player movements through peripheral vision (Williams *et al.*, 2004) and anticipate more quickly to their environment (Eccles & Tenenbaum, 2004). As less gifted soccer players are less able to anticipate movements of teammates and opponents, team measures based on individual player positions like centroid positions are less coupled presumably. This may imply that absolute values of inter-team distance are key performance indicators, whereas the strength of the relation is an indicator of playing level. However, as this study provides no evidence for the degree in which the teams' expertise level influenced the results, future research in this area is warranted.

## Conclusions

We examined the effect of pitch size manipulations on surface area difference, longitudinal and lateral inter-team distance and spatial-temporal patterns thereof. As expected, manipulations of pitch length and width sparked changes in team measures in those directions respectively. Most importantly, we also showed that there is a crossover

effect of pitch length manipulation on lateral inter-team distance and from pitch width manipulations on longitudinal inter-team distance. In sum, we showed that changes in pitch size trigger changes in teams' interactive behaviour in small-sided soccer games. This is an important tactically relevant finding that, when aware of, coaches can use to their advantage in training and matches.

### *Practical implications*

Pitch size manipulations of length and width affect teams' spatial-temporal interaction patterns in that particular direction.

The crossover effect of length and width manipulations mean that changes in either one triggers a response by teams in both directions.

Coaches must carefully choose the type of small-sided game in training, as interaction patterns vary depending on pitch dimensions.

&lt;

&lt;

&lt;

### *Acknowledgement*

*The authors thank Frans Lefeber for assisting with data collection. No external support was received for this study.*

## REFERENCES

1. > Araújo, D., K. Davids, K., Bennett, S.J., Button, C & Chapman, G. (2004). Emergence of sport skills under constraints, in *Skill Acquisition in Sport: Research, Theory and Practice* (ed. by A. M. Williams and N. J. Hodges), Routledge, Taylor & Francis, London, 409-433.
2. > J. Bourbousson, J., Sève, C. & McGarry, T. (2010). Space-time coordination dynamics in basketball: Part 2. The interaction between the two teams. *Journal of Sports Sciences*, 28(3), 349-358.
3. > Coutts, A.J., Rampinini, E., Marcora, S.M., Castagna, C. & Impellizzeri, F.M. (2009). Heart rate and blood lactate correlates of perceived exertion during small-sided soccer games. *Journal of Science and Medicine in Sport*, 12(1), 79-84.
4. > Corbetta, D. & Thelen, E. (1996). The developmental origins of two-handed coordination: A dynamic perspective. *Journal of Experimental Psychology: Human Perception and Performance*, 22, 502-522.
5. > Davids, K., Araújo, D. & Shuttleworth, R. (2005). Applications of Dynamical Systems Theory to Football in *Science and Football V* (ed. by T. Reilly, J. Cabri and D. Araújo), Routledge, Taylor & Francis, London, 537-550.
6. > Frencken, W.G.P. & Lemmink, K.A.P.M. (2008) Team kinematics of small-sided soccer games: A systematic approach in *Science and Football VI* (ed. by T. Reilly and F. Korkusuz), Routledge, London and New York, 161-166.
7. > Frencken, W.G.P., Lemmink, K.A.P.M. & Delleman, N.J. (2010). Soccer-specific accuracy and validity of the local position measurement (LPM) system. *Journal of Science and Medicine in Sport*, 13, 641-645.
8. > Frencken, W.G.P., Lemmink, K.A.P.M., Delleman, N.J. & Visscher, C. (2011). Oscillations of centroid position and surface area of soccer teams in small-sided games. *European Journal of Sport Science*, 4, 215-223.
9. > Frencken, W.G.P., De Poel, H.J., Visscher, C. & Lemmink, K.A.P.M. (2012). Variability of inter-team distances associated with match events in elite-standard soccer. *Journal of Sports Sciences*. 30(12), 1207-1213.
10. > Gréhaigine, J.F., Bouthier, D. & David, B. (1997). Dynamic-system analysis of opponent relationships in collective actions in soccer. *Journal of Sports Sciences*, 15, 137-149.
11. > Hill-Haas, S.V., Dawson, B., Impellizzeri, F.M. & Coutts, A.J. (2011). Physiology of small-sided games training in football. A systematic review. *Sports Medicine*, 41(3), 199-220.
12. > McGarry, T., Anderson, D.I., Wallace, S., Hughes, M.D. & Franks, I.M. (2002). Sport competition as a dynamical self-organizing system. *Journal of Sports Sciences*, 20, 771-781.
13. > Newell, K.M. (1986). Constraints on the development of coordination in Motor development in children: Aspects of coordination and control (ed. by M.G. Wade and H.T.A. Whiting), Martinus Nijhoff Publishers, Amsterdam, 341-361.
14. > Passos, P., Milho, J., Fonseca, S., Borges, J., Araújo, D. & Davids, K. (2011). Interpersonal distance regulates functional grouping tendencies of agents in team sports. *Journal of Motor Behavior*, 43(2), 155-163.
15. > Tessitore, A., Meeusen, R., Piacentini, M.F., Demarie, S. & Capranica, L. (2006). Physiological and technical aspects of "6-a-side" soccer drills. *Journal of Sports Medicine and Physical Fitness*, 46, 36-43.
16. > Travassos, B., Araújo, D., Vilar, L. & McGarry, T. (2011). Interpersonal coordination and ball dynamics in futsal (indoor football). *Human Movement Science*, 30(6), 1245-1259.
17. > Stelzer, A., Pourvoyeur, K. & Fischer, A. (2004). Concept and application of LPM. A novel 3-D local position measurement system. *IEEE Transactions on Microwave Theory and Techniques*, 52, 2664-2669.
18. > Williams, A.M., Janelle, C.M. & Davids, K. (2004). Constraints on the search for visual information in sport. *International Journal of Sport and Exercise Psychology*, 2, 301-318.
19. > Eccles, D.W. & Tenenbaum, G. (2004). Why an expert team is more than a team of experts: A social-cognitive conceptualization of team coordination and communication in sport. *Journal of Sport & Exercise Psychology*, 26, 542-560.







# INTER-TEAM DISTANCES AND THEIR VARIABILITY IN EILITE-STANDARD SOCCER MATCHES

Wouter G.P. Frencken <sup>1,2,3</sup>

Harjo J. de Poel <sup>1</sup>

Chris Visscher <sup>1</sup>

Koen A.P.M. Lemmink <sup>1,2</sup>

*1 University Medical Center Groningen,  
University of Groningen  
Center for Human Movement Sciences  
Groningen  
The Netherlands*

*2 Hanze University of Applied Sciences  
School of Sports Studies  
Groningen  
The Netherlands*

*3 Football Club Groningen  
Groningen  
The Netherlands*

## *Abstract*

This study evaluates if longitudinal and lateral inter-team distance and variability thereof differ between match halves over a series of elite-standard matches. Additionally, the influence of tactical elements (opposition strength, goals scored and match outcome) was evaluated. Sample included positional data (AMISCO Pro®) of twenty-seven home matches of an elite-standard German soccer club. From the positional data, we calculated mean and standard deviations of longitudinal and lateral inter-team distances per half per match. A factorial repeated measures analysis of variance was performed. The results indicate that longitudinal and lateral inter-team distances and variability are significantly greater in the second half. The observed effects are moderate to large, values range between 0.74 and 0.87. No other significant main effects or interaction effects were established. Results can indicate that different functional inter-team distances may be present in a match and teams switch between these inter-team distances depending on the context of the match. Alternatively, the increased inter-team distances in the second half can be caused by fatigue. Moreover, effects of opposition strength, scoreline and match outcome on physical and technical performance do not transfer to team-team interactions. Further research is required to evaluate the underlying physiological or strategic mechanisms of increased inter-team distances and variability thereof.

*In: International Journal of Performance Analysis in Sport, (Submitted)*

**Tactics,  
Interactions,  
Dynamics,  
Performance analysis,  
Team sports**

# INTRODUCTION

Interactions between players are omnipresent in team sports like soccer. These interactions occur between players of the same team, or between players of opposing teams and underlie pattern formation (Grehaigine *et al.*, 1997; McGarry *et al.*, 2002). In several studies, player-player interactions have been investigated (e.g. Bourbousson *et al.*, 2010a, Travassos *et al.*, 2012). It can be anticipated that comparable interactions between teams are present as well, as has been demonstrated in some studies (e.g. Bourbousson *et al.*, 2010b; Duarte *et al.*, 2012; Frencken *et al.*, 2011; Frencken *et al.*, 2012). The interaction patterns allow for quantification of tactical concepts and can offer alternative performance indicators at team or match level (Lemmink & Frencken, 2009; 2010).

Longitudinal and lateral inter-team distances have been proposed as measures for quantification of these interaction processes between teams (Frencken *et al.*, 2012). This is the difference in distance between the centroid positions of both teams, longitudinally and laterally respectively. The centroid is the mean position of all outfield players of a team. Recent research on team-team interactions indicates that the centroid positions of two teams are entrained to a high degree in small-sided soccer games and full-sized matches, indicated by high correlations (Frencken *et al.*, 2011; Frencken *et al.*, 2012). Moreover it was demonstrated that during a single match, periods of high variability in longitudinal and lateral inter-team distances were present. These periods were predominantly associated with pressurizing the attacking or defending team and dead-ball situations like cheering after goals (Frencken *et al.*, 2012). For periods of high variability prior to goals and goal-scoring opportunities, limited evidence was found. After periods of high variability, stability was reestablished meaning balance between the teams was restored. As such, this soccer match adhered to principles of complex systems. However, up to date it remains unclear if these findings can be generalized to other matches.

Additionally, it was established that variability of longitudinal and lateral inter-team distances was greater in the second half (Frencken *et al.*, 2012) and it was argued that this indicated that more space became available for players, which could be of tactical relevance. This is in line with findings on physiological and technical demands in soccer that demonstrates decreased performance in the second half for various variables (e.g. Carling *et al.*, 2008). To illustrate, players cover less distance in the second half, number of sprints is decreased in the second half and lactate production is increased. Moreover, several factors related to tactics like opposition strength, formation and scoreline have shown to influence the work rate of soccer players (e.g. Rampinini *et al.*, 2007; Bradley *et al.*, 2011; O'Donoghue & Tenga, 2001). Likewise physical performance, technical performance is impaired in the second half, demonstrated by a drop in the number of completed passes for example (e.g. Rampinini *et al.*, 2009).



Because physical and technical performance are impaired in the second half, we performed the current study to evaluate if longitudinal and lateral inter-team distances and its variability differ between match halves over a series of elite-standard matches of one team. The second aim was to evaluate if other tactical constructs related to performance, i.e. opposition strength, number of goals scored by the team and match outcome influenced values of inter-team distances and variability. We expect that inter-team distances and its variability differ between match halves.

## Methods

Twenty-seven home matches of an elite-standard German soccer club in the 2008-2009 (n=21) and 2009-2010 (n=6) season were analyzed. The sample included six UEFA Champions League® matches (group stage: n=5, second round: n=1) and twenty-one German Bundesliga® matches. Nine of these national league matches were played against teams that finished top half in that respective season and twelve versus teams that finished bottom half ultimately. The number of goals scored by the team under study was; no goals: n=4, one goal: n=5, two goals: n=7, three goals: n=6, four goals: n=4, 5 goals: n=1. Overall, this resulted in 16 wins, 7 draws and 4 losses. In all matches, positional data of players were collected with AMISCO Pro® video-based tracking system at 10 Hz. See Carling *et al.* (2005) and Carling *et al.* (2008) for technological background information and Zubillaga (2006) for details on validity and reliability.

From the positional data, we calculated centroid positions according to the protocol described by Frencken *et al.* (2011), where the centroid position of a team refers to the average x,y position of the outfield players. From the teams' centroid positions, the mean longitudinal and lateral inter-team distances per half were derived (for calculations, see Frencken *et al.*, 2012). Additionally, variability

of longitudinal and lateral inter-team distances per half was established by calculating standard deviations of both inter-team distances. Periods of cheering after goals and periods in which players were substituted were removed from the data as these moments have shown to affect inter-team distances (Frencken *et al.*, 2012). In case of a goal scored, the excluded period was defined as the moment the ball crossed the line when a goal was scored until the referee whistled to restart the match. For substitutions, this period was defined as the moment between the referee's whistle that players could be substituted until the referee whistled to restart the match.

In the statistical analysis, the mean longitudinal and lateral inter-team distances and the longitudinal and lateral variability were treated as separate variables. A factorial repeated measures analysis of variance was performed. The following between-subjects factors were used: final ranking (top half and bottom half), number of goals scored by the home team in a match (0, 1, 2, 3, 4, and 5) and match outcome (win, draw, loss). Match half (first and second half) was the within-subjects factor for repeated measures. Effect-sizes (Partial Eta<sup>2</sup>) were also calculated for match half per variable, with values larger than 0.8 denoted as large effect. Statistical significance was accepted if  $p < 0.05$ .

## Results

The results indicated that all four variables differed significantly between first and second half. The observed effects were moderate to large for longitudinal inter-team distance (0.75), lateral inter-team distance (0.87), longitudinal variability (0.74) and lateral variability (0.85). For all inter-team distances and variability thereof, greatest values were obtained for the second half (table 1). Apart from the difference between first and second half, no main effects were established for opposition strength, goals scored and match outcome, nor were interaction effects observed.

## Discussion

In this study, we evaluated if differences could be established between match halves in longitudinal and lateral inter-team distances and its variability in elite-standard soccer. We also evaluated if opposition's final ranking, match outcome and goals scored by the home team influenced the results. Our primary findings are that longitudinal and lateral inter-team distances and variability thereof differ between first and second half, with highest values obtained for the second half (table 1). No main effects or interaction effects were found for opposition strength, number of goals scored by the home team and match outcome.

*Table 1. Descriptive statistics of (variability of) longitudinal and lateral inter-team distances (n=27). All four variables differ significantly between first and second half.*

	First Half		Second Half			
	Inter-team distance (m)	(95% CI)	Min - Max	Inter-team distance (m)	(95% CI)	Min - Max
Longitudinal	6.8 ± 0.5	(6.6 - 7.0)	6.0 - 7.9	9.7 ± 1.6	(9.1 - 10.3)	6.8 - 13.0
Lateral	0.3 ± 0.3	(0.2 - 0.4)	0.0 - 0.9	1.1 ± 0.7	(0.8 - 1.4)	0.0 - 2.3
Longitudinal variability	2.2 ± 0.3	(2.1 - 2.3)	1.7 - 3.1	3.1 ± 0.6	(2.9 - 3.3)	2.2 - 4.2
Lateral variability	2.3 ± 0.2	(2.3 - 2.4)	1.9 - 2.7	3.3 ± 0.5	(3.1 - 3.5)	2.5 - 4.1

These findings could indicate that the increased inter-team distances and corresponding variability originates in the match itself and is not related to factors like opposition strength or match outcome. One explanation is that different functional inter-team distances exist. Passos *et al.* (2011) have demonstrated that during interactions between small groups of players in rugby, the inter-personal distance changed depending on the task. The same can be applied to team-team interactions. Both the longitudinal and lateral inter-team distances can be attracted to multiple functional distances. This allows for combinations of functional distances in which the game state is stable and possibly switches between different strategies given the context of the match. Analysis of short intervals, for instance every single second or per sample, can offer further insights into the presence of multiple functional inter-team distances, longitudinally or laterally, in transition moments or attacking and defensive phases of play.

An alternative explanation for the increased inter-team distances in the second half is fatigue, because several indicators of physical performance like distance covered (Carling *et al.*, 2008) and technical performance like pass completion (Rampinini *et al.*, 2009) tend to decrease. A decreased physical performance caused by fatigue in the second half occurs on three occasions: after short-term intense pe-

riods, at the start of the second half, and towards the end of the match (Mohr *et al.*, 2005). Repeated pressure on individual players has been suggested as a mechanism (Carling *et al.*, 2008), as has reduced motivation as a function of score-line (O'Donoghue & Tenga, 2001). As a result, players can keep up with that pace for a while, but not sustain that for prolonged periods, particularly towards the end of a match. As such, players are less able to meet the physical demands of the match. This could explain both the increased inter-team distances as well as the increased variability. At least, this warrants research on shorter intervals to confirm this. Another fatigue-related explanation that has been suggested is that players adopt a pacing strategy to maintain the physical performance until the end of the match (Carling *et al.*, 2008). This implies that players can moderate their effort depending on the physical or tactical demands in a match and could as such influence the interaction patterns.

Finally, we did not establish differences in inter-team distances and variability for different opponent strength, match outcome and goals scored by the home team. Although opposition strength, formation and score line have been shown to affect physical performance of individual players (e.g. Rampinini *et al.*, 2007; Bradley *et al.*, 2011; O'Donoghue & Tenga, 2001), this does not transfer to team-team interactions in this study. It could be

that the methodological approach taken in this study is a limitation. Here, we evaluated the inter-team distances in two halves. Possibly, an evaluation of fixed time-periods after goals are scored, e.g. 5 minutes, can further improve the analysis. Although we did not establish a relation with match outcome, our findings are of significance to performance. For example, if the longitudinal inter-team distance difference between first and second half is 3 m on average (table 1), this could mean that individual players have more space to exploit. At elite-standard playing level, this implies more time to handle the ball and increased difficulty to pressurize the attacking team. This can be used as an advantage in by coaches. Nevertheless, more work is required.

To conclude, in the current study a series of elite-standard matches was analyzed to establish differences between match halves for longitudinal and lateral inter-team distances and variability thereof. Systematically, higher values were obtained in the second half for these variables, irrespective of opposition strength, number of goals scored by the team and match outcome. Coaches and trainers can exploit this knowledge and adopt a playing strategy. Further research is required to evaluate the underlying physiological or strategic mechanisms of increased inter-team distances and variability.

## REFERENCES

1. > Bourbousson, J., Sève, C., & McGarry, T. (2010a). Space-time coordination dynamics in basketball: Part 1. Intra- and inter-couplings among player dyads. *Journal of Sports Sciences*, 28, 339-347.
2. > Bourbousson, J., Sève, C., & McGarry, T. (2010b). Space-time coordination dynamics in basketball: Part 2. The interaction between the two teams. *Journal of Sports Sciences*, 28, 349-358
3. > Bradley PS, Carling C, Archer D, Roberts J, Dodds A, Di Mascio M, Paul D, Diaz AG, Peart D, Krstrup P. (2011) The effect of playing formation on high-intensity running and technical profiles in English FA Premier League soccer matches. 29(8) 821-830.
4. > Carling, C., Williams, A.M. & Reilly, T. (2005) *Handbook of soccer match analysis. A systematic approach to improving performance*. London, Routledge.
5. > Carling, C., Bloomfield, J., Nelsen, L., & Reilly, T. (2008). The role of motion analysis in elite soccer: Contemporary performance measurement techniques and work rate data. *Sports Medicine*, 38, 839-862.
6. > Duarte, R., Araújo, D., Freire, L., Folgado, H., Fernandes, O. & Davids K. (2012). Intra- and inter-group coordination patterns reveal collective behaviors of football players near the scoring zone. *Human Movement Science*, <http://dx.doi.org/10.1016/j.humov.2012.03.001>
7. > Frencken, W. G. P., De Poel, H. J., Visscher, C. & Lemmink, K. A. P. M. (2012). Variability of inter-team distances associated with match events in elite-standard soccer. *Journal of Sports Sciences*. 30(12), 1207-1213.
8. > Frencken, W. G. P. & Lemmink, K. A. P. M. (2008). Team kinematics of small-sided soccer games: A systematic approach. In T. Reilly & F. Korkusuz (Eds.), *Science and Football VI* (161-166). London and New York: Routledge.
9. > Frencken, W. G. P., Lemmink, K. A. P. M., Delleman, N. J. & Visscher (2011). Oscillations of centroid position and surface area of soccer teams in small sided games. *European Journal of Sport Science*, 11(2), 215-223.
10. > Gréhaigne, J. F., Bouthier, D., & David, B. (1997). Dynamic-system analysis of opponent relationships in collective actions in soccer. *Journal of Sports Sciences*, 15, 137-149.
11. > Lemmink, K. A. P. M. & Frencken, W. G. P. (2009). Physiological and tactical match analyses in ball team sports; New perspectives. In A. Lorenzo, S. J. Ibáñez & E. Ortega (Eds.), *Aportaciones teóricas y practicas para el baloncesto del futuro*. Sevilla: Wanceulen Editorial Deportiva.
12. > Lemmink, K. A. P. M. & Frencken, W. G. P. (2010). Analyses of tactical patterns in ball team sports: from 1 vs. 1 to small sided games. *International Journal of Sport Psychology*, 13(4), 88-89.
13. > McGarry, T., Anderson, D. I., Wallace, S. A., Hughes, M. D., & Franks, I. M. (2002). Sport competition as a dynamical self-organizing system. *Journal of Sports Sciences*, 20, 771-781
14. > Mohr, M., Krstrup, P. & Bangsbo J. (2005) Fatigue in soccer: a brief review. *Journal of Sports Sciences*, 23 (6) 593-9.
15. > Rampinini, E., Impellizeri, F. M., Castagna, C., Coutts, A.J., Wisløff, U. (2009). Technical performance during soccer matches of the Italian Serie A league: effect of fatigue and competitive level. *Journal of Science and Medicine in Sport*, 12(1) 227-33.
16. > Rampinini, E., Coutts, A.J. & Castagna C. (2007) Variation in top level soccer match performance. *International Journal of Sports Medicine*, 28 (12), 1018-24.
17. > O'Donoghue, P.G. & Tenga, A. (2001). The effect of score-line on work rate in elite soccer. *Journal of Sports Sciences*, 19 (2): 25-6.
18. > Passos, P., Davids, K., Araújo, D., Paz, N., Minguéns, J. & Mendes, J. (2011). Networks as a novel tool for studying team ball sports as complex social system. *Journal of Science and Medicine in Sport*, 14, 170-176.
19. > Travassos, B., Araújo, D., Vilar, L. & McGarry, T. (2011) Interpersonal coordination and ball dynamics in futsal (indoor football). *Human Movement Science*. 30(6), 1245-59
20. > Zubillaga, A. (2006). *La actividad del jugador de fútbol en alta competición: análisis de variabilidad. (Football player's activity in high level competition: Variability analysis)* Thesis Doctoral: Universidad de Malaga.







# GENERAL DISCUSSION

## *Aims of the thesis*

In the current thesis, a new approach to match analysis is introduced. Two aspects mark its innovative nature. First, continuous positional data of players is used differently compared to traditional approaches. In contrast to calculations of distance and speed per player, calculations of distances between players and teams are performed to analyze spatio-temporal patterns. The positional data of players is thought to be a continuous reflection of tactical positioning of those players (Lemmink & Frencken, Accepted; Passos *et al.*, 2011). Second, the dynamical systems framework is adopted as theoretical framework, which has conceptualized individual and team sports (e.g. McGarry *et al.*, 2002). Although it is a rather uncommon theoretical framework within the sports performance analysis domain, its theory and tools are used for continuous analysis of small-sided training games and full-sized matches. This approach can deal with spatio-temporal patterns, facilitates analysis at the level of individual players, clusters of players or large groups of players (Davids *et al.*, 2007) and may potentially allow predictions of future performance. As such, a first attempt has been made to evaluate if critical match periods that could be invisible to the naked eye can be identified through positional data in this thesis.

Thus, the main goals of this thesis were to introduce new performance measures grounded in positional data, to evaluate these performance measures in small-sided training games and full-sized matches and to examine if task manipulations constrain interactive team behaviour. Because parts of the data collection took place in a training setting with an innovative tracking technology, the final aim was to establish the accuracy and validity of this tracking system. A series of experimental and observational studies in which youth, adult and (non) elite-standard soccer players participated, served to achieve these goals.

## *Key findings*

In chapter two of this thesis, the accuracy and validity of an innovative tracking technology in soccer-specific conditions is reported. The results indicate that in static and dynamic conditions, the system produces highly accurate positional data. In addition, the system underestimates distance covered compared to the golden standard, but the magnitude of the difference is smaller than observed for other technologies (Edgecomb & Norton, 2006; Coutts & Duffield, 2008). Likewise, speed measurements are systematically lower compared to the golden standard. Again, the magnitude of the difference is smaller than for other systems



(Witte & Wilson, 2005) and the error increases for higher running speeds. So, the tracking system can be considered an accurate and valid tool for recording positions, distances covered and speeds of players in soccer.

Based on positional data obtained with the tracking system, two geometrical configurations, centroid position and surface area, were calculated. These are thought to reflect the flow of attack and defence in soccer. Chapter three contains detailed information on the calculations and experimental data on teams' centroid positions and surface areas in small-sided soccer games. The greatest correlation values ( $>0.94$ ) between teams' centroid positions were observed for longitudinal centroid positions compared to the lateral centroid positions. This means that teams' positions are entrained in longitudinal direction most. As such, the longitudinal direction seems the dominant direction of play. This finding is systematically reproduced in other experiments in small-sided games and a full-sized match, reported in chapters five and four respectively, and is in accordance with previous literature (Bourbousson *et al.*, 2010; Lames *et al.*, 2008).

In addition to this finding, it was demonstrated in chapter three that goals and goal-scoring opportunities displayed a specific characteristic. The teams' centroid

positions swapped positions longitudinally prior to a goal or goal-scoring opportunity in 53 % of the cases. No specific pattern was observed for teams' lateral centroid positions. Based on these findings, the experiment reported in chapter five was performed.

From the teams' longitudinal and lateral centroid positions, longitudinal and lateral inter-team distances were derived. High variability in these measures could indicate critical match periods. The findings demonstrate that periods of high variability were associated with movements of players and teams after longitudinal and lateral passes and reorganization in dead-ball moments like collective cheering after scoring, free kicks and throw-ins. Although 19% of goals and goal-scoring opportunities, i.e. one of two goals and two of fourteen goal-scoring opportunities, were preceded by high variability in inter-team distance, this percentage is considerably lower compared to the 53% reported in chapter three. The most likely explanation is that in small-sided games, individual players influence the centroid position more than in full-sized matches and calculations thereof must be fine-tuned.

The emergent patterns of centroid positions, inter-team distances and surface areas in small-sided games and full-sized matches described in chapters three and four are constrained by the per-

formance context (Newell, 1986). Moreover, task manipulations in soccer practice are frequently applied and influence physical performance for instance (Hill-Haas *et al.*, 2011). Therefore, chapter five reports an investigation on the effect of task constraint manipulations on interaction patterns. Four small-sided soccer games were played on different pitch sizes. It was demonstrated that pitch size manipulations of length and width affect teams' spatio-temporal interaction patterns in that particular direction. For example, a shorter pitch results in more longitudinal in-phase movement of teams' centroids. In addition a crossover effect of length and width manipulations was observed. This means that changes in pitch length or width initiate a response by teams' behaviour in longitudinal and lateral directions.

Variability is present in many performance metrics, e.g. high-speed activities in elite-standard soccer (Gregson *et al.*, 2010). Furthermore, research indicates decreased second half match performance for several physical and technical performance measures (Carling *et al.*, 2008). It is likely that this also applies to tactical performance metrics like inter-team distances. Therefore, mean inter-team distances and variability thereof were investigated over a series of elite-standard soccer matches in chapter six. Results indicate greater longitudinal and

lateral inter-team distances in the second half and increased variability. Possibly, altered strategy and/or fatigue explain these findings.

### *Limitations*

To put the key findings from this thesis in perspective, some limitations need to be discussed. The limitations concern the validity of measures and the methodological approach. For both categories, two limitations will be addressed.

With respect to the validity of measures, it can be argued that the calculations of centroid position and surface area do not correspond with the true match situation. For example, in chapter three it was demonstrated that centroid positions crossed prior to goals and goal-scoring opportunities in small-sided games, supporting previous findings. Although a similar pattern was found prior to one of two goals and two of fourteen goal-scoring opportunities in a regular full-sized soccer match, this pattern was less prominent. The reason for this may be that movements of single players cancel each other out in full-sized matches. Thus, the relative contribution of one player is greater in small-sided games. As mentioned in chapters three and four, a major assumption for calculations of these geometrical configurations is that each player's contribution is equal at every instant. From a coaches' perspective, it seems

unlikely that this is the case. So, it appears to be crucial to apply weight factors to each individual player after determination of players that are deemed important at every single instant. Factors that could potentially serve as selection mechanism to determine important or influential players may come from coaches or scientists. In case of the former, proximity to the ball, running directions relative to other players or skill of players seem promising. For the latter, principal component analysis or cross-correlations of speed or acceleration profiles may provide a sound basis for sub-unit selection. These analyses may be suited to identify players that instantaneously 'cooperate' most strongly.

The consensus of coaches for establishing the 3-s window, applied in chapters four and five, is the second matter related to validity of measures. Scientific evidence that informs about transition periods after loss of ball possession in team sports is absent. Similarly, it is unclear to what extent coaches (dis)agree on tactical concepts. In chapter four, a threshold of 3 s was applied after a panel of expert coaches reached consensus on the maximal time they allow their teams to be unorganized after loss of ball possession. The analysis presented in chapter four was also performed with shorter time-scales of 2 and 2.5 s. This did not change the outcome. It could be that none of these time-scales

are relevant for performance, because these 3-s windows are based on potential dogma's that exist in coaching. The aim of this thesis is to introduce a new way of performance analysis. This pioneering preferably involves limited influence of current dogmas. However, in order to provide a face-valid anchor, coaching expertise was relied upon.

Furthermore, two methodological concerns need to be addressed. First, throughout this thesis the number of small-sided games and full-sized matches are limited. Three and four small-sided games are evaluated in chapters three and five respectively. One full-sized match was used in chapter four. Nevertheless, the small number of small-sided games provided a satisfactory number of goals and goal-scoring opportunities for our analysis, yet more small-sided games and full-sized matches would have improved statistical power. This mainly lacks in the study described in chapter five because data constitutes of a single game per condition. This limitation is acknowledged there as such. However, the correlations for longitudinal and lateral centroid positions and surface areas in this study correspond with previous correlations reported in chapter three. In addition, findings are in line with previous research (e.g. Bourbousson *et al.*, 2010b; Lames *et al.*, 2008). As such, these arguments support the validity of

the findings reported in chapter five. In chapter four, where critical match periods were associated with match events, only one match was analyzed. Because this match is of the highest possible elite-standard quality, this is a representative sample. Because data of elite-standard players and high quality is difficult to obtain momentarily because of limited availability of tracking systems in match situations, this convenience sample outweighs methodological disadvantages.

The second methodological concern is that the skill levels of players that participated in experiments presented in this thesis vary. The sample includes elite-standard youth players, adult amateurs and elite-standard professional soccer players. This can compromise interpretations and generalizations of results. For example, in chapter five lower correlation and coupling values were observed than in chapter three. The explanation that was offered was a difference in skill level between the elite-standard youth players and adult amateur players (Eccles & Tenenbaum, 2004). It remains unclear how, and in what direction, this skill difference affects pattern formation. Nevertheless, the findings in the subsequent chapters support each other. For example correlations are greatest for longitudinal measures throughout this thesis, regardless of player skill, number of small-sided games or matches or study design.

### *Future directions*

Throughout this thesis, specific suggestions for future research have been put forward at the end of chapters three to six. Because this thesis is among first scientific explorations in the tactical performance analysis domain, several general future directions are available that can build on the current thesis' knowledge and clear directions can be provided. This section contains an overview of most vital future avenues.

First, effort needs to be devoted to the definition of criteria that allow for constitution of sub-units within a team. In chapter four, the assumption that players within a team cancel out each other's moves or do not contribute equally to instantaneous performance was raised. Determination of key players at every instant is required to make the next step in tactical performance analysis.

Second, there is an urgent need for further comparisons of small-sided games and full-sized matches. Here, evaluation of small-sided games (chapters three and five) and full-sized matches (chapters four and six) took place. This allows for assumptions of differences in interactive team behaviour and speculations on interactive player behaviour. Yet, a clear comparison has not yet been made. Because small-sided games are frequently used for

tactical training by trainers and coaches and its physiological stimulus has been described thoroughly (Hill-Haas *et al.*, 2011), the tactical validity and tactical merits remain unclear and this requires further work.

Third, after fine-tuning and confirmation of inter-team distance, surface areas and other geometrical configurations as tactical performance indicators, these measures may be used for evaluation of tactical development of youth players or teams. Performing analyses presented in this thesis could enhance the tactical learning process. The first piece of evidence for differences in exploring space in small-sided games by teams of different age has been provided (Folgado *et al.*, in revision).

Fourth, because team tactical analyses become possible with positional data of players and measures are developed, intervention studies can be applied. Different type of strategies like 4-4-2 or 4-3-3 can be objectively related to winning, losing or creating and preventing goal-scoring opportunities. Also, it becomes easier to replicate tactical approaches of future opponents in small-sided or full-sized training games.

Fifth, ball position needs to be incorporated in the analysis. Recent research demonstrates that player

behaviour is strongly influenced by ball position (Travassos *et al.*, 2011). However, at this point in time there is a technological limitation to tracking the exact position of the ball, particularly in real training sessions of official matches.

Sixth, other tactical concepts should be subject to a scientific approach. In this thesis, the in-phase pattern of teams' centroids and antiphase patterns of surface areas reflect the rhythmic flow of attack and defence in soccer. However, across all team sports and specifically soccer, there are more tactical concepts available for which positional data can be used. To illustrate, recent research has focused on pass-options in elite-standard soccer (Frencken *et al.*, 2012). There the availability of players for receiving the ball from a teammate was determined using positional data of players and ball. This serves as an example for future tactical performance analysis.

### *Conclusions, theoretical implications and practical implications*

In this thesis a new approach to tactical performance analysis has been promoted. The main aims of this thesis were to identify variables that capture the interaction processes of teams and evaluated these in small-sided soccer games and full-sized matches. In addi-

tion, the aim was to determine critical match periods from the interaction process from positional data of players. Next to that, a task constraint was manipulated to evaluate its effect on the interaction processes. Because positional data was crucial for this thesis, a tracking system used for data collection for experiments in a training setting was validated. A series of experiments has been performed and were presented in the current thesis.

#### *Conclusions*

The main conclusions that can be drawn from these studies are:

- > Accurate and valid positional data of players can be obtained with a tracking system in a training setting.
- > Teams' centroid positions and surface areas describe the rhythmic flow of attack and defence in small-sided soccer games and full-sized matches. More evidence is presented for centroid positions.
- > Longitudinal and lateral inter-team distances describe the interaction process between teams.
- > Critical match periods can be established from positional data.
- > Patterns of interactive-team behaviour change after pitch size manipulations.
- > Inter-team distances and variability thereof increase in the second half.

#### *Theoretical implications*

This thesis adds to scientific body of knowledge in many ways.

First, it adds to the body of literature that confirms traits of dynamical systems in team sports, here soccer.

Second, the study reported in chapter 4 assumes that soccer can be considered a dynamical system and aimed to predict future critical match events. Although this approach requires further fine-tuning, it marks an advance in sports science literature as no attempts have been made to predict future performance so far.

Third, the adoption of the dynamical systems framework approach in tactical performance analysis is rather new. Especially at the level of interacting teams, research is limited. The thesis provides a basis for tactical performance analysis that is strongly grounded in theory. It may open a new scientific domain, in which positional data of players in training and matches that has been available for considerable time now, is used to investigate mechanisms that underlie and explain performance.

#### *Practical implications*

Next to the scientific evidence and challenges that this thesis offers, it has some practical consequences as well. Given the adoption of an uncommon theoretical framework for tactical performance analysis and the limitations that have been discussed, ready-to-use advice for sports practitioners is not overly available. Neverthe-

less, practical implications that can be deduced from this thesis are reported below.

First, accurate positional data of players is available during matches or training. Next to physiological analyses, team-training sessions should be monitored to gather information on tactical performance. This tactical information can be used for either evaluation of previous performance, real-time during training and matches or for preparations of future performance

Second, the inter-team distances could be the underlying mechanism for successful tactical performance.

Third, hypothesized patterns that are part of current dogmas, like creating space when in ball possession and restricting space when not, may occur less prominently as previously thought of. Therefore, practitioners open to new types of performance analysis are the first to benefit from this.

Fourth, when designing training practitioners and scientists must be aware that the task at hand not only influences physical performance, but also interactive tactical team performance

Finally, this thesis sets a new standard for sports scientists to use positional data differently. Clear indications for future studies

were given and this thesis paves the way for follow-up work as such. For further enhancement of the developmental process of tactical performance analysis, the challenge is to create a research context in which practitioners like trainers and coaches work alongside sport scientists, statisticians, mathematicians and experts from other domains. This improves the quality of the available data and the mutual understanding between practice and science. From this, both disciplines will reap big rewards.

## REFERENCES

1. > Bourbousson, J., Sève, C., & McGarry, T. (2010b). Space-time coordination dynamics in basketball: Part 2. The interaction between the two teams. *Journal of Sports Sciences*, 28, 349-358.
2. > Carling, C., Bloomfield, J., Nelsen, L., & Reilly, T. (2008). The role of motion analysis in elite soccer: Contemporary performance measurement techniques and work rate data. *Sports Medicine*, 38, 839-862.
3. > Coutts A.J. & Duffield, R. (2010) Validity and reliability of GPS devices for measuring movement demands of team sports. *Journal of Science and Medicine in Sport*, 13(1), 133-135.
4. > Davids, K., Araújo, D., Button, C., & Renshaw, I. (2007). Degenerate brains, indeterminate behavior and representative tasks: Implications for experimental design in sport psychology research. In G. Tenenbaum & B. Eklund (Eds.), *Handbook of Sport Psychology* (pp. 224-244). Hoboken, NJ: John Wiley.
5. > Eccles, D.W. & Tenenbaum, G. (2004). Why an expert team is more than a team of experts: A social-cognitive conceptualization of team coordination and communication in sport. *Journal of Sport & Exercise Psychology*, 26, 542-560.
6. > Edgcomb S.J. & Norton, K.I. (2006). Comparison of global positioning and computer-based tracking systems for measuring player movement distance during Australian Football. *Journal of Science and Medicine in Sport*, 9, 25-32.
7. > Folgada, H., Lemmink, K.A.P.M., Frencken, W.G.P., & Sampaio, J. (2012). Length, width and centroid distance as measures of youth football teams tactical performance during small-sided games. *European Journal of Sport Science*. DOI:10.1080/17461391.2012.730060
8. > Frencken, W.G.P., Olthof, S. & Lemmink, K.A.P.M. (2012). Pass-options in elite soccer. *Book of abstracts of the 3rd World Conference on Science and Soccer (WCSS)*. Ghent, Belgium.
9. > Gregson, W., Drust, B., Atkinson, G & Salvo VD. (2010). Match-to-match variability of high-speed activities in premier league soccer. *International Journal of Sports Medicine*, 31(4), 237-42.
10. > Hill-Haas, S.V., Dawson, B., Impellizeri, F.M. & Coutts, A.J. (2011) Physiology of small-sided games training in football. A systematic review. *Sports Medicine*, 41(3), 199-220.
11. > Lames, M., Erdmann, J., & Walter, F. (2008). Oscillations in football - order and disorder in spatial interactions between the two teams. *Book of abstracts of the 2nd ICCSS*, 114-115.
12. > Lemmink, K.A.P.M. & Frencken, W.G.P. (accepted). Tactical match analysis: perspectives from a dynamical systems approach and examples from soccer. In McGarry, T., O'Donoghue, P. & Sampaio, J. (Eds.), *Routledge Handbook of Sports Performance Analysis*. London and New York: Routledge.
13. > Newell, K.M. (1986). Constraints on the development of coordination in Motor development in children: Aspects of coordination and control (ed. by M.G. Wade and H.T.A Whiting), *Martinus Nijhoff Publishers*, Amsterdam, 1986, 341-361.
14. > Passos, P., Milho, J., Fonseca, S., Borges, J., Araújo, D. & Davids, D. (2011) Interpersonal distance regulates functional grouping tendencies of agents in team sports. *Journal of Motor Behaviour*, 43(2), 155-163.
15. > Travassos, B., Araújo, D., Vilar, L. & McGarry, T. (2011) Interpersonal coordination and ball dynamics in futsal (indoor football). *Human Movement Science*, 30(6), 1245-1259.
16. > Witte, T.H. & Wilson, A.M. (2005). Accuracy of WAAS-enabled GPS for the determination of position and speed over ground. *Journal of Biomechanics*, 38, 1717-1722.







# SUMMARY

In the current thesis, a new approach to match analysis is introduced. Two reasons underpin its innovative nature; an alternative use of continuous positional data of players and adoption of the dynamical systems framework for tactical performance analysis. The main aims of this thesis were to introduce new tactical performance measures grounded in positional data, to evaluate them in small-sided training games and full-sized matches and to examine if task manipulations constrain interactive team behaviour. Because a considerable part of the data collection for this thesis took place in a training setting with a tracking technology, the final aim was to establish the accuracy and validity of this tracking system. For these purposes, a series of experimental and observational studies involving youth, adult and (non) elite-standard soccer players was performed.

Because the spatial and temporal resolution of data collection systems must be of high quality for tactical performance analysis, chapter 2 reports on the accuracy and validity of the local position measurement (LPM) system. Hereto, a validation protocol was designed that covered flaws in commonly used validation protocols. Therefore, the protocol (see chapter 2 for further details) contained straight and curved trajectories with soccer-specific distances and directional changes that were completed at preferred walking and sprinting speeds. Findings revealed high degrees of accuracy and validity, surpassing (semi)automatic video-based technologies and GPS. It was concluded that the system is an accurate and valid tool for collecting player positions and speeds and can be used for various purposes, including physiological and tactical analyses.

In chapter 3, surface areas and centroid positions of two teams were introduced as geometrical measures that could provide a collective variable for tactical performance analysis and as such describe the interaction process between two teams. Patterns of these measures were qualitatively analyzed and associated to goal-scoring opportunities and goals in three small-sided games. About half of all goal-scoring opportunities and goals display a distinct pattern, i.e. a change in the relative longitudinal position of the centroids of both teams, often characterized by crossings of centroid positions. Additionally, it appeared that the speed at which the teams change their centroid positions could underlie the development of goals. Finally, these findings supported the notion that invasive team sports like soccer exhibit traits of a dynamical system.

Based on the observations in chapter 3, the longitudinal and lateral inter-team distances were calculated. These were defined as the absolute differences between the longitudinal or lateral centroid positions of the teams respectively. In chapter 4, critical match periods were derived from periods of high variability in longitudinal and lateral inter-team distances in one elite-standard match. Periods with highest variability were extracted from both inter-team distances and



video-analyzed. These periods included one of two goals, corresponding with the 50 % as observed in small-sided games in chapter 3. Only two out of fourteen goal-scoring opportunities were included. Most critical match periods were associated with events in which the ball was passed longitudinally or laterally and players of one of the teams collectively changed running direction. So, this supported findings reported in chapter 3, but provided limited further evidence. In chapter 5, the effect of task modifications on pattern development of longitudinal and lateral inter-team distances and the surface area difference was evaluated. For this purpose, four small-sided games were played. Experimental conditions involved no manipulation, a pitch length manipulation, a pitch width manipulation and a combination of pitch length and width manipulation. It was demonstrated that pitch size manipulations of length and width affect teams' spatio-temporal interaction patterns in that corresponding direction. In addition a crossover effect of length and width manipulations was observed. This means that changes in pitch length or width initiate a response in teams' interactive behaviour in longitudinal and lateral directions.

Because many performance indicators vary from match to match and because they are frequently associated with match outcome, chapter 6 reports on the variation of (variability of) inter-team distances in a series of 27 elite-standard soccer matches. Additionally, it evaluates differences in inter-team distances for four variables: between match halves (first and second), between number of goals scored per match by the home team (0 to 5), between match outcomes (win, draw, loss) and between opposition strengths (top half finish and bottom half finish). It was established that longitudinal and lateral inter-team distances and corresponding variability were larger in the second half. No differences were observed for the other variables. This can indicate that an altered tactical strategy was adopted or accumulated fatigue influences tactical performance measures like inter-team distances.

In chapter 7, the main findings, conclusions and theoretical and practical implications are reported. It is concluded that accurate and valid positional data of players can be obtained for tactical performance analysis. Additionally, teams' centroid positions and surface areas describe the rhythmic flow of attack and defence in small-sided soccer games and full-sized matches. The inter-team distances represent the interaction processes between two teams. The emergent interaction patterns are constrained and depend on pitch size in small-sided games. Furthermore, critical match periods including goals and goal-scoring opportunities can be derived from the inter-team distances. Finally, inter-team distances and variability thereof increase in the second half. These findings have various theoretical and practical implications and offer concrete directions for future research.

# SAMENVATTING

In dit proefschrift wordt een nieuwe manier van tactische wedstrijdanalyse geïntroduceerd. Twee kenmerken markeren het innovatieve aspect; positie-data van spelers wordt op een alternatieve manier gebruikt en de dynamische systeem theorie wordt als theoretisch kader gebruikt voor tactische prestatieanalyse. De hoofddoelen van dit proefschrift zijn het introduceren van nieuwe tactische prestatie-indicatoren gebaseerd op positiedata, evaluatie daarvan in kleine partijtjes en reguliere wedstrijden en evaluatie van het effect van het manipuleren van de taak op het interactieve gedrag van teams. Aangezien een behoorlijk deel van de dataverzameling in een trainingsetting heeft plaatsgevonden middels tracking technologie, was het laatste doel het vaststellen van de nauwkeurigheid en validiteit van dat tracking systeem. Om deze doelen te realiseren, is een serie experimentele en observatiestudies uitgevoerd bij jeugdige, volwassen, amateur en elite voetballers.

Aangezien de ruimtelijke en temporele resolutie van het meetsysteem van hoge kwaliteit moeten zijn voor tactische prestatieanalyse, wordt in hoofdstuk 2 de nauwkeurigheid en validiteit van het Local Position Measurement (LPM) systeem beschreven. Daarvoor werd een valideringsprotocol ontworpen, waarin tekortkomingen van veelgebruikte protocollen zijn vermeden. Het protocol (zie hoofdstuk 2 voor meer details) bestond daarom uit rechte en gebogen trajecten met voetbalspecifieke afstanden en richtingsveranderingen, die zijn gewandeld en gesprint op voorkeursnelheid. Er werd een hoge mate van nauwkeurigheid en validiteit vastgesteld, die (semi) automatische videotecnologieën en GPS overtreft. De conclusie was dat het trackingsysteem een nauwkeurig en valide middel is om positie en snelheid te meten dat voor verschillende doeleinden kan worden gebruikt, waaronder fysiologische en tactische analyses.

In hoofdstuk 3 werden de middelpunten en oppervlaktes van twee teams geïntroduceerd als geometrische maten die een collectieve variabele zouden kunnen zijn voor tactische prestatieanalyse en als zodanig het interactieproces tussen de twee teams kunnen beschrijven. Patronen van deze maten zijn kwalitatief geanalyseerd en gerelateerd aan momenten van kansen en doelpunten in drie kleine partijtjes. Ongeveer de helft van alle kansen en doelpunten werd gekenmerkt door een specifiek patroon: een verandering in de longitudinale posities van de middelpunten, vaak gekenmerkt door het kruisen van de middelpunten. Daarnaast leek de snelheid waarmee de teams het middelpunt verplaatsten samen te hangen met het ontstaan van doelpunten. Tenslotte werd geconstateerd dat teamsporten zoals voetbal inderdaad kenmerken bezitten van een dynamisch systeem.

Gebaseerd op de observaties in hoofdstuk 3, werden longitudinale en laterale inter-team afstanden berekend. Deze afstanden zijn gedefinieerd als de absolute afstanden tussen respectievelijk de longitudinale en laterale positie van de middelpunten van de teams. In hoofdstuk 4 werden kritieke wedstrijdperiodes afgeleid op basis van periodes van hoge variabiliteit in longitudinale en laterale inter-team afstanden in één reguliere wedstrijd op het allerhoogste spelniveau. De periodes met de hoogste variabiliteit van beide inter-team afstanden werden geselecteerd en bijbehorende videofragmenten werden geanalyseerd. Onder de geselecteerde momenten was één van de twee doelpunten, wat overeenkomt met de in kleine partijspelen geobserveerde 50 % die in hoofdstuk 3 gerapporteerd werd. Slechts twee van de veertien kansen werden geïncludeerd. De meeste kritieke wedstrijdperiodes hingen samen met momenten waarop de bal in de lengterichting of zijwaarts werd gepast en de spelers van één team collectief van looprichting veranderden. Deze bevindingen ondersteunen de resultaten van hoofdstuk 3, maar leveren beperkt additioneel bewijs.

In hoofdstuk 5 is het effect van taak manipulaties op longitudinale en laterale inter-team afstanden en het oppervlakteverschil geëvalueerd. Daarvoor zijn vier kleine partijen gespeeld. De experimentele condities waren: geen aanpassing, aanpassing van de veldlengte, aanpassing van veldbreedte en een combinatie van aanpassingen van veldlengte en veldbreedte. Resultaten wijzen uit dat veldlengte en veldbreedte manipulaties de tijd-ruimte interactiepatronen beïnvloeden in de richting waarin gemanipuleerd is. Daarnaast hebben beide manipulaties ook effect op de andere richting. Dat betekent dat veranderingen in veldlengte of veldbreedte een reactie veroorzaken in het interactiepatroon in zowel longitudinale als laterale richting.

Aangezien veel prestatie-indicatoren van wedstrijd tot wedstrijd variëren en gerelateerd worden aan wedstrijduitkomsten, wordt in hoofdstuk 6 de variatie in (de variabiliteit van) inter-team afstanden over een serie van 27 wedstrijden op het allerhoogste spelniveau besproken. Daarnaast worden verschillen in inter-team afstanden voor vier variabelen geëvalueerd: tussen helften (eerste en tweede), tussen aantal gescoorde doelpunten per wedstrijd (0 tot en met 5), tussen wedstrijdresultaten (winst, gelijkspel, verlies) en tussen sterkte van de tegenstanders (bovenste helft ranglijst en onderste helft ranglijst). Resultaten wijzen uit dat longitudinale en laterale inter-team afstanden en bijbehorende variabiliteit groter zijn in de tweede helft. Er zijn geen verschillen gevonden voor de overige variabelen. Dit kan wijzen op een veranderde tactische strategie in de tweede helft of dat vermoeidheid tactische prestatie-indicatoren zoals inter-team afstand beïnvloedt.

In hoofdstuk 7 worden de belangrijkste bevindingen, conclusies en theoretische en praktische implicaties besproken. Er wordt geconcludeerd dat er nauwkeurige en valide positiedata beschikbaar is voor tactische prestatieanalyse. Daarnaast wordt geconcludeerd dat de posities van de middelpunten van de teams het proces van aanvallen en verdedigen beschrijven in kleine partijspelen en reguliere wedstrijden, waarbij de inter-team afstanden de interactieprocessen tussen de teams representeren. De patronen die daarbij ontstaan worden beïnvloed door taakmanipulaties, zoals het spelen op velden met specifieke afmetingen. Tevens kunnen uit de inter-team afstand- en kritieke wedstrijdperiodes zoals kansen en doelpunten worden afgeleid. Tenslotte, inter-team afstanden en bijbehorende variabiliteit is groter in de tweede helft. Deze bevindingen hebben diverse theoretische en praktische implicaties en bieden concrete aanknopingspunten voor vervolgonderzoek.







# CURRICULUM VITAE

Wouter Gijsbert Petrus Frencken is geboren op 6 augustus 1982 te Tilburg. Wouter studeerde van 2000 tot 2005 gezondheidswetenschappen aan de Universiteit Maastricht, met Bewegingswetenschappen als afstudeer-richting. Zijn afstudeerproject werd uitgevoerd bij de TVM-schaatsploeg en resulteerde in een scriptie getiteld: 'Muscle activation patterns in elite speed skating'.

In februari 2006 is Wouter gestart met promotieonderzoek naar bewegingsgedrag van voetballers en teams in kleine partijspelen en wedstrijden bij het Centrum voor Bewegingswetenschappen te Groningen. Daar heeft hij gewerkt aan het ontwikkelen van nieuwe wedstrijd- en trainingsanalyses in het voetbal op basis van positiedata. De middels trackingsystemen verkregen positiedata werd gebruikt om de dynamica van teamprestatie te analyseren, waarbij de interactie tussen twee teams centraal stond. Tevens werd de nauwkeurigheid en validiteit van een trackingsysteem geëvalueerd. Dit promotieonderzoek rondde hij in 2012 af. Gedurende het promotieonderzoek heeft hij een groot aantal reviews en afstudeerprojecten (bachelor en master) begeleid op thema's rondom wedstrijdanalyse. Ook was hij betrokken bij diverse onderwijsmodules, is hij 2 jaar aiovertegenwoordiger geweest in het MT, zijn diverse cursussen gevolgd bij de onderzoeksschool en heeft hij meegewerkt aan de analyses achter de Tv-documentaire 'How to win the FIFA World Cup'. Gedurende de periode 2006-2012 heeft hij intensief samengewerkt met sportbonden en professionele clubs in verschillende teamporten.

Wouter is tussen 2009 en 2012 ook actief geweest als embedded scientist bij AZ Alkmaar. In het InnoSportNL-project 'geavanceerde wedstrijdanalyse voetbal' werkte hij aan de ontwikkeling en operationalisatie van tactische voetbal parameters, resulterend in diverse innovatieve softwaremodules om tactische concepten te meten. Tegelijkertijd verzorgde hij de terugkoppeling van de fysieke wedstrijdprestatie van AZ Alkmaar op basis van positiedata aan de technische staf en ontwikkelde hij diverse fysieke prestatie-indicatoren.

Sinds september 2011 is Wouter in dienst bij het Hanze Instituut voor Sportstudies als coördinator, docent en onderzoeker. De werkzaamheden omvatten het begeleiden van afstudeerprojecten, het verzorgen van onderwijs en het doorontwikkelen van technologieën in de topsporthal van het SportsFieldLab Groningen.



Vanaf oktober 2011 is hij in dienst als sportwetenschapper bij FC Groningen. De werkzaamheden omvatten het articuleren van vragen vanuit de sportpraktijk, het opzetten en coördineren van onderzoeksprojecten gerelateerd aan prestatieverbetering en prestatieontwikkeling van voetballers in training en wedstrijden, het implementeren van wetenschappelijke kennis en methoden in de sportpraktijk en het versterken van de relatie met de Rijksuniversiteit Groningen, de Hanzehogeschool Groningen en het Universitair Medisch Centrum Groningen.

# LIST OF PUBLICATIONS

## *International journals*

- > *Frencken, W.G.P., De Poel, H.J., Visscher, C. & Lemmink, K.A.P.M.* (Submitted). Inter-team distances and their variability in elite-standard soccer matches. *International Journal of Performance Analysis in Sport*.
- > Olthof, S.B.H., *Frencken, W.G.P. & Lemmink, K.A.P.M.* (Submitted). The older, the wider: on-field tactical performance of elite-standard youth soccer players in small-sided games. *Journal of Sports Sciences*.
- > *Frencken, W.G.P., Van der Plaats, J., Visscher, C. & Lemmink, K.A.P.M.* (Accepted). Size matters; pitch dimensions constrain inter-team distances and surface area difference in small-sided soccer games. *Journal of Systems Science and Complexity; Complex Systems and Sports*.
- > Folgado, H., Lemmink, K.A.P.M., *Frencken, W.G.P., & Sampaio, J.* (Accepted) Length, width and centroid distance as measures of youth football teams tactical performance during small-sided games. *European Journal of Sport Science*. DOI:10.1080/17461391.2012.730060
- > *Frencken, W.G.P., De Poel, H.J., Visscher, C. & Lemmink, K.A.P.M.* (2012). Variability of inter-team distances associated with match events in elite-standard soccer. *Journal of Sports Sciences*, 30(12), 1207-1213.
- > *Frencken, W.G.P., Lemmink, K.A.P.M., Delleman, N.J. & Visscher, C.* (2011). Oscillations of centroid position and surface area of soccer teams in small-sided games. *European Journal of Sport Science*, 4, 215-223.
- > *Frencken, W.G.P., Lemmink, K.A.P.M. & Delleman, N.* (2010) Soccer-specific accuracy and validity of the local position measurement (LPM) system. *Journal of Science and Medicine in Sport*, 13, 641-645.
- > [abstract] Lemmink, K.A.P.M. & *Frencken, W.G.P.* (2010). Analyses of tactical patterns in ball team sports: from 1 vs. 1 to small-sided games. *International Journal of Sport Psychology*, 14(supplementum 4), 88-89.
- > [abstract] *Frencken, W.G.P. & Lemmink, K.A.P.M.* (2007). Successful performance in soccer: team kinematics of goal-scoring opportunities in small-sided soccer games. *Journal of Sports Science & Medicine* 6(supplementum 10), 19-20.

## *Dutch journals*

- > Tijdink, H., *Frencken, W.G.P. & Lemmink, K.A.P.M.* (2011). Versnellingen en vertragingen in het zaalvoetbal. *Sportgericht* 65(5), 38-42.

## Book chapters

- Lemmink, K.A.P.M. & *Frencken, W.G.P.* (accepted). Tactical match analysis: Perspectives from a dynamical systems approach and examples from soccer. In McGarry, T., O'Donoghue, P. & Sampaio, J. (Eds.), *Routledge Handbook of Sports Performance Analysis*. London and New York: Routledge.
- Brink, M.S., *Frencken, W.G.P.* & Lemmink, K.A.P.M. (2010). Overbelasting in de sport: waar ligt de grens? In Bongers, R., Caljouw., S, Hartman, E. & Den Otter, A.R. (Eds.), *Smart Movements; 25 jaar Bewegingswetenschappen*. Interfacultair Centrum voor Bewegingswetenschappen, Universitair Medisch Centrum Groningen, Rijksuniversiteit Groningen, 63-65.
- Frencken, W.G.P.*, Brink, M.S. & Lemmink, K.A.P.M. (2010). Het (on)gelijk van Crujff? In Bongers, R., Caljouw., S, Hartman, E. & Den Otter, A.R. (Eds.), *Smart Movements; 25 jaar Bewegingswetenschappen*. Interfacultair Centrum voor Bewegingswetenschappen, Universitair Medisch Centrum Groningen, Rijksuniversiteit Groningen, 136-138.
- Lemmink, K.A.P.M, Brink, M.S. & *Frencken, W.G.P.* (2010). Voetbalconditie: survival of the fit-test? In Bongers, R., Caljouw., S, Hartman, E. & Den Otter, A.R. (Eds.), *Smart Movements; 25 jaar Bewegingswetenschappen*. Interfacultair Centrum voor Bewegingswetenschappen, Universitair Medisch Centrum Groningen, Rijksuniversiteit Groningen, 60-62.
- Lemmink, K.A.P.M. & *Frencken, W.G.P.* (2009) Physiological and tactical match analyses in ball team sports; New perspectives. In A. Lorenzo, A., Ibáñez, S.J. & Ortega, E. (Eds.), *Aportaciones teóricas y practicas para el baloncesto del futuro*. Wanceulen Editorial Deportiva, SL, Sevilla, Spain.
- Frencken, W.G.P.* & Lemmink, K.A.P.M. (2008). Team kinematics of small-sided soccer games: A systematic approach. In Reilly, T. & Korkusuz, F. (Eds.), *Science and Football VI* (pp. 161-166). London and New York: Routledge.

## Abstracts

- Frencken, W.G.P.* & Lemmink, K.A.P.M. (2013). Inter-team dynamics in soccer: evidence from small-sided games and full-sized matches. Invited symposium at 18th annual Congress of the European College of Sport Science (ECSS), Barcelona, Spain.
- Frencken, W.G.P.*, Olthof, S. & Lemmink, K.A.P.M. (2012). Pass options in elite soccer. 3rd World Conference on Science and Soccer (WCSS). Ghent, Belgium.
- Frencken, W.G.P.*, Van der Plaats, J. & K.A.P.M. Lemmink (2012). Pitch dimensions affect interactive team behaviour in small-sided games. 3rd World Conference on Science and Soccer (WCSS). Ghent, Belgium.
- Lemmink, K.A.P.M. & *Frencken, W.G.P.* (2012). Measuring tactical performance in soccer; where to go? 3rd World Conference on Science and Soccer (WCSS). Ghent, Belgium.

- > *Frencken, W.G.P., De Poel, H.J. & Lemmink, K.A.P.M. (2011) Analysis of game dynamics and related game events in 11v11 soccer. 7th World Congress on Science & Football (WCSF). Nagoya, Japan.*
- > *Lemmink, K.A.P.M. & Frencken, W.G.P. (2011). Tactical match analysis in soccer: new perspectives? 7th World Congress on Science & Football (WCSF). Nagoya, Japan.*
- > *Lemmink, K.A.P.M. & Frencken, W.G.P (2010). Tactical match analyses in soccer: New perspectives from a dynamical system approach? 3rd International Congress Complex Systems in Medicine and Sport (ICCSMS). Kaunas, Lithuania.*
- > *Frencken, W.G.P. (2009). Tactiek is meetbaar. Dribbelen met wetenschap in de lage landen, Gent, Belgium.*
- > *Frencken, W.G.P., Visscher, C. & Lemmink, K.A.P.M. (2009). Oscillations in small-sided soccer games. 14th annual Congress of the European College of Sport Science (ECSS). Oslo, Norway.*
- > *Frencken, W.G.P., Otten, E., van der Plaats, J., Visscher, C & Lemmink, K.A.P.M. (2009). Taking initiative in small-sided soccer games. 14th annual Congress of the European College of Sport Science (ECSS). Oslo, Norway.*
- > *Lemmink, K.A.P.M. & Frencken, W.G.P. (2008) Analyses of tactical patterns in ball team sports: from 1 versus 1 to small sided games. 2nd International Congress on Complex Systems in Sport (ICCS). Funchal, Portugal.*
- > *Frencken, W.G.P. & Lemmink, K.A.P.M. (2008). Small-sided soccer games and goal-scoring opportunities. 2nd International Congress on Complex Systems in Sport (ICCS). Funchal, Portugal.*
- > *Lemmink, K.A.P.M. & Frencken, W.G.P. (2008) Analysis of Player Interactions in Small-sided soccer Games. 3rd Clinical Sports Medicine Conference. University of Cape Town, Cape Town, South Africa.*
- > *Frencken, W.G.P., Otten, E., Visscher, C. & Lemmink, K.A.P.M. (2008) Analysis of Player Interactions in Small-sided Soccer Games. 13th Annual Congress of the European College of Sport Science (ECSS). Technical University of Lisbon, Estoril, Portugal.*
- > *Frencken, W.G.P. & Lemmink, K.A.P.M. (2007). Successful Performance in Soccer; Team Kinematics of Goal-scoring Opportunities in Small-sided Soccer Games. Vith World Congress on Science & Football (WCSF). Antalya, Turkey.*
- > *Frencken, W.G.P. & Lemmink, K.A.P.M. (2006) Successful Performance in Soccer; Do Team Dynamics Lead to Goal-scoring opportunities? European Workshop on Ecological Psychology 9 (EWEP), University of Groningen, Groningen, the Netherlands.*

*Honours & awards*

1st prize poster presentation – Boer, F., Lemmink K.A.P.M. & *Frencken*,  
*W.G.P.* (2011). VvBN-studentendag. Accelerations in futsal; a new approach <  
 BCN travel grant – research visit to Norwegian School of Sport Science (2010) <

*Magazines, Radio & TV*

Magazines (2007-2012):

Bright, NWT, Volkskrant, Volkskrant Banen Magazine, KIJK, <<<<<<  
 Coachen, De Voetbaltrainer <<

Radio (2008-2012):

Radio 1, Radio 2, BNR Nieuwsradio <<<

TV (2010):

RTL Nieuws, RTL7 <<





# DANKWOORD

In de afgelopen jaren heb ik met volle overgave en ontzettend veel plezier gewerkt aan dit proefschrift en alle nevenwerkzaamheden. Daar hebben veel mensen, bewust of onbewust, aan bijgedragen. Iedereen bedankt!

*Dr. Lemmink;* Beste Koen, dank. Ik heb geweldig genoten de periode waarin je me begeleid hebt. Je hebt me leren (net)werken en ontelbaar veel mogelijkheden gegeven om me persoonlijk en inhoudelijk te ontwikkelen. Hulde daarvoor, want dat is ongebruikelijk heb ik gemerkt. Met je ongeëvenaarde vooruitziende blik en je vermogen om overal kansen te zien in plaats van bedreigingen, ben je voor mij de personificatie van 'lead by example' en zodoende een groot voorbeeld op de werkvloer. Hoewel het promotietraject de directe aanleiding was voor onze samenwerking, kijk ik uit naar het vervolgen en continueren van die samenwerking!

*Prof. dr. Visscher;* Beste Chris. Dank, voor de mogelijkheden en bijdrage op verschillende fronten bij de vervolmaking van diverse artikelen en proefschrift. Tevens bedankt voor je inzet om een goed vervolg te geven aan de tijd na het promotieonderzoek. Ik waardeer het zeer.

*Leden van de Beoordelingscommissie; prof.dr. Diercks, prof.dr. Koning, prof.dr. Savelsbergh,* dank voor de tijd die jullie besteed hebben aan de evaluatie en beoordeling van mijn proefschrift.

*Dr. De Poel;* Beste Harjo, ik heb je in een later stadium van mijn promotieonderzoek betrokken. Dank voor de kritische (theoretische) noten die je gekraakt hebt, alsook de bijdragen aan de papers. Ik waardeer je inzet enorm.

*BW-collega's;* Ik ben altijd met een lach naar BW gekomen. Dat is jullie verdienste en mijn dank is groot daarvoor. Het secretariaat, de AIO's (van Toen als Nu), *Michel Brink, Barbara Huijgen, Beldien van der Linde, Richard Dik, Gert-Jan Pepping, Raoul Bongers* en *Paul van Wilgen* verdienen een speciale vermelding. Hoewel jullie me de laatste maanden relatief weinig hebben gezien, zijn jullie cruciaal geweest voor een goede mix van inhoud en ontspanning. Tevens wil ik iedereen bedanken voor het meespelen in de EK-, WK- en tourpools!

*Consortiumpartners; Jos van Dijk, Frans Lefeber, Nico Delleman, Edward de Boer en Rob Renaud,* ik waardeer jullie inzet voor het beschikbaar stellen van meet-systemen, het faciliteren, ondersteunen en begeleiden van metingen, ontwikkelen van software en het meedenken en kritisch beschouwen van ideeën. Daarnaast hebben we de afgelopen jaren op andere gebieden dan het proefschrift intensief en prettig samen gewerkt. Dankzij jullie heb ik een beter zicht gekregen op de procesmatige en economische kant van sport(wetenschap), niet geheel onbelangrijk!

*Deelnemers aan studies, begeleiders & coaches, dank!* Zonder jullie was dit proefschrift er überhaupt niet geweest. Datzelfde geldt voor studenten die de afgelopen jaren betrokken zijn geweest. *Ivo, Jorrit en Sigrid*, jullie zijn belangrijk geweest in projecten direct gerelateerd aan dit proefschrift en de voortzetting daarvan. De ontelbare uren in de auto op en neer vanuit Groningen naar Alkmaar zijn een prettige herinnering aan die samenwerking.

*Geir Jordet*. Everybody needs examples. To me, you have been and still are, an important one. Your work ethics strongly appeal to me. You've been truly inspiring, both inside and outside the office. I am also glad for the research visit in Oslo you offered me. Many thanks for your contribution. *Bruno Travassos, Duarte Araújo, Aaron Coutts and Franco Impellizeri*. You guys have also been instrumental for my personal and scientific development for various reasons.

*Collega's van AZ, FC Groningen & Instituut voor Sportstudies*. Bedankt allen voor de samenwerking tot op heden. Op naar een mooie, sportieve toekomst! *Robert de Groot en Peter Jeltema*, jullie hebben mij haarfijn in laten zien wat het verschil is tussen wetenschappelijk relevant/interessant en praktisch relevant/interessant. Dit plaatst onderzoek, kennis en proefschriften in een mooi perspectief en neem ik mee in het vervolg van mijn carrière.

*Michel Brink & Thomas Frencken, paranimfen*. Dank dat jullie mijn paranimfen wilden zijn! Fijn om tussen jullie in te mogen staan!

*Thomas Frencken*. Ik ben op de vorm van het proefschrift minstens net zo trots als op jou en de inhoud en dat is helemaal jouw verdienste! Bedankt voor je betrokkenheid, inzet en expertise bij de weg naar het proefschrift, het ontwerp van het proefschrift en alles wat daar totaal niets mee te maken heeft!

*Michel Brink*. Iemand zei ooit: de meest vormende periode in je leven is je promotietraject en diegene met wie je dat het meest intensief deelt, vaak je kamergenoot, wordt een 'friend for life'. Dat hebben we geweten! Geweldig bedankt voor de gesprekken over de (on)zin van publiceren, proefschriften, sportwetenschap, carrière en veel niet-werkgerelateerde zaken! Ik hoop dat we dit kunnen voortzetten en waar mogelijk intensiveren. Máár, reken je niet te snel rijk, vriend, want je weet: "ik zou ... als het zou moeten!!!"

*Ria, Gijs & Thomas*, de interesse voor, en steun bij, de totstandkoming van dit proefschrift wordt vanzelfsprekend enorm gewaardeerd. Jullie aanmoedigingen om van jongs af aan het beste uit mezelf te halen en voornamelijk na te jagen wat ik leuk vond zodat ik het maximale uit mezelf kon halen om daar vervolgens goed in te worden en plezier aan te beleven, is voor mij de meest wijze en belangrijkste levensles geweest. Dat zal me altijd bijblijven en probeer ik aan iedereen door te geven. Veel dank.

